

PRODUCT SPECIFICATIONS

Elkay Commercial Electronic Sensor Scrub/Handwash Battery Powered Wall Mount Faucet Chrome. Faucet has a flow rate of 1.5 GPM, and is made of Chrome-plated Brass material, with a Electronic Control Module valve. Faucet requires 1 faucet holes.

Mounting Type:	Wall Mount
Special Features:	Hands Free Sensor Activated Solid Brass Construction
Finish:	Chrome (CR)
Handle Type:	Sensor Operated (Hands Free)
Deck Clearance:	6-5/8"
Spout Reach:	7-1/2"
Spout Height:	10-7/8"
Hole Drillings:	1
Material:	Chrome-plated Brass
Valve Type:	Electronic Control Module
Valve Connection:	1/2" NPT Female
Flow Rate:	1.5 GPM
Faucet Hole Size (min):	1-1/8"
Spout Swing Rotation:	0°
Spout Type:	Fixed Spout

Special Note: in-line filter with clean out trap and flexible supply hose.



Chrome (CR)



Included with Product: AC plug-in and battery holder with 4 AA batteries pre-installed

A Century of Tradition and Quality. For more than 100 years, Elkay has been making innovative products and providing exceptional customer care. We take pride in offering plumbing products that make life easier, inspire change and leave the world a better place.

Product Compliance: ADA & ICC A117.1
ASME A112.18.1/CSA B125.1
NSF 372 (lead free)
NSF 61 (Q≤1)



Complies with ADA & ICC A117.1 accessibility requirements when installed according to the requirements outlined in these standards.

[Clean and Care Manual \(PDF\)](#)
[Installation Instructions \(PDF\) - 98517C](#)
[Warranty \(PDF\)](#)

PART: _____ QTY: _____

PROJECT: _____

CONTACT: _____

DATE: _____

NOTES: _____

APPROVAL: _____

In keeping with our policy of continuing product improvement, Elkay reserves the right to change product specifications without notice. Please visit elkay.com for the most current version of Elkay product specification sheets. This specification describes an Elkay product with design, quality, and functional benefits to the user. When making a comparison of other producers' offerings, be certain these features are not overlooked.

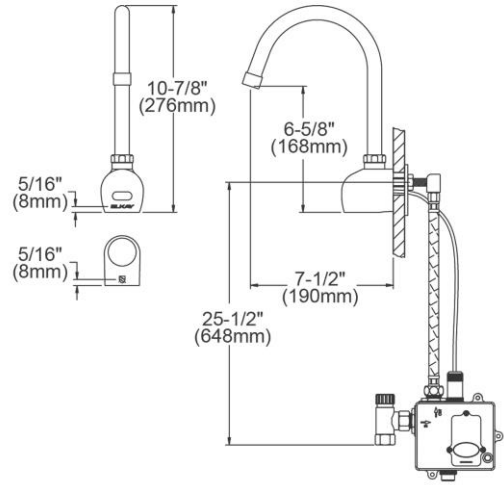

In keeping with our policy of continuing product improvement, Elkay reserves the right to change product specifications without notice. Please visit elkay.com for the most current version of Elkay product specification sheets. This specification describes an Elkay product with design, quality, and functional benefits to the user. When making a comparison of other producers' offerings, be certain these features are not overlooked.

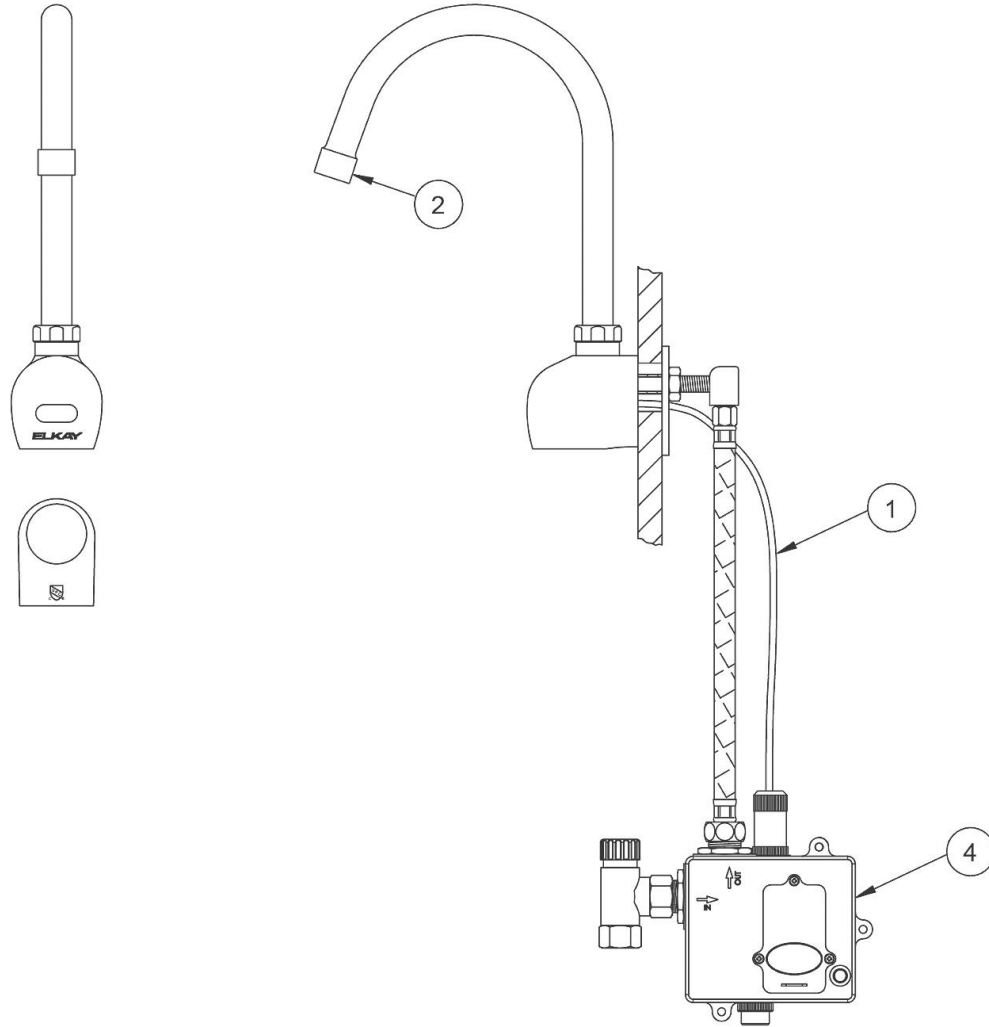

ITEM	PART NUMBER	PART DESCRIPTION
1	98567C	SENSOR ASSEMBLY
2	98542C	AERATOR ASSEMBLY
3	1000003975	POWER ADAPTER (NOT SHOWN)
4	1000003976	CONTROL BOX

In keeping with our policy of continuing product improvement, Elkay reserves the right to change product specifications without notice. Please visit elkay.com for the most current version of Elkay product specification sheets. This specification describes an Elkay product with design, quality, and functional benefits to the user. When making a comparison of other producers' offerings, be certain these features are not overlooked.