

Stainless Steel 24" x 22" x 27" Wall Hung ADA Sink Enviro Kit with Eyewash + Faucet + Drain + Mixing Valve Model(s) EWSF12422T

SPECIFICATIONS

PRODUCT SPECIFICATIONS

Stainless Steel 24" x 22" x 27" Wall Hung ADA Sink Enviro Kit with Eyewash + Faucet + Drain + Mixing Valve. Sink is manufactured from 14 gauge 304 Stainless Steel with a Brushed finish, Center drain placement.

Material:	304 Stainless Steel
Finish:	Brushed
Gauge:	14
Weight Without Packaging:	125
Number of Bowls:	1
Sink Dimensions:	24" x 22" x 37"
Bowl 1 Dimensions:	20" x 17-1/4" x 6-1/2"
Drainboard Location:	No drainboard
Backsplash Height:	4.5
Drain Size:	3-1/2" (89mm)
Drain Location:	Center



Included with Product: one hydropower sensor faucet,
one JG1800LH eyewash station,
one J35SSF drain

A Century of Tradition and Quality.

For more than 100 years, Elkay has been making innovative products and providing exceptional customer care. We take pride in offering plumbing products that make life easier, inspire change and leave the world a better place.



Product Compliance: ASME A112.19.3/CSA B45.4
ADA & ICC A117.1

Faucet: NSF 372 (lead free)
ASME A112.18.1/CSA B125.1
NSF 61 (Q≤1)

Accessory: ASME A112.18.2/CSA B125.2
ASSE 1069
ASSE 1070
ASSE 1017
NSF 372 (lead free)



Sinks are listed by IAPMO® as meeting the applicable requirements of the Uniform Plumbing Code®, International Plumbing Code®, and National Plumbing Code of Canada.



Complies with ADA & ICC A117.1 accessibility requirements when installed according to the requirements outlined in these standards.

[Clean and Care Manual \(PDF\)](#)
[Installation Instructions \(PDF\) - 2000003113](#)
[Installation Instructions \(PDF\) - 2000000714](#)
[Warranty \(PDF\)](#)

PART: _____ QTY: _____

PROJECT: _____

CONTACT: _____

DATE: _____

NOTES: _____

APPROVAL: _____

In keeping with our policy of continuing product improvement, Elkay reserves the right to change product specifications without notice. Please visit elkay.com for the most current version of Elkay product specification sheets. This specification describes an Elkay product with design, quality, and functional benefits to the user. When making a comparison of other producers' offerings, be certain these features are not overlooked.

Stainless Steel 24" x 22" x 27" Wall Hung ADA Sink Enviro Kit
with Eyewash + Faucet + Drain + Mixing Valve
Model(s) EWSF12422T

SPECIFICATIONS

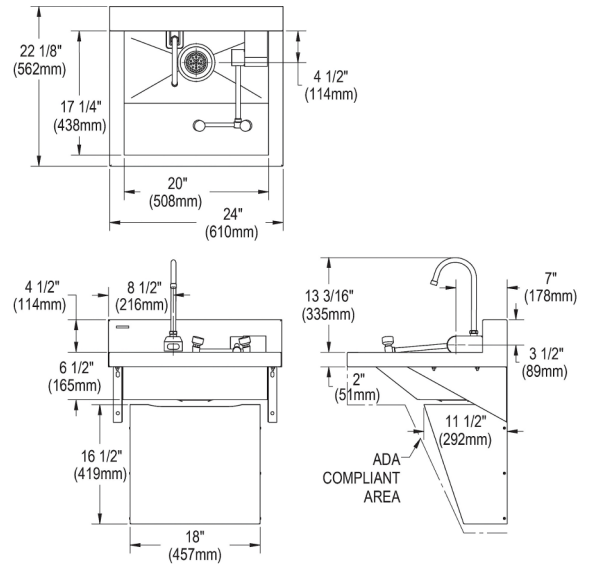

In keeping with our policy of continuing product improvement, Elkay reserves the right to change product specifications without notice. Please visit elkay.com for the most current version of Elkay product specification sheets. This specification describes an Elkay product with design, quality, and functional benefits to the user. When making a comparison of other producers' offerings, be certain these features are not overlooked.

Stainless Steel 24" x 22" x 27" Wall Hung ADA Sink Enviro Kit
with Eyewash + Faucet + Drain + Mixing Valve

SPECIFICATIONS

Model(s) EWSF12422T

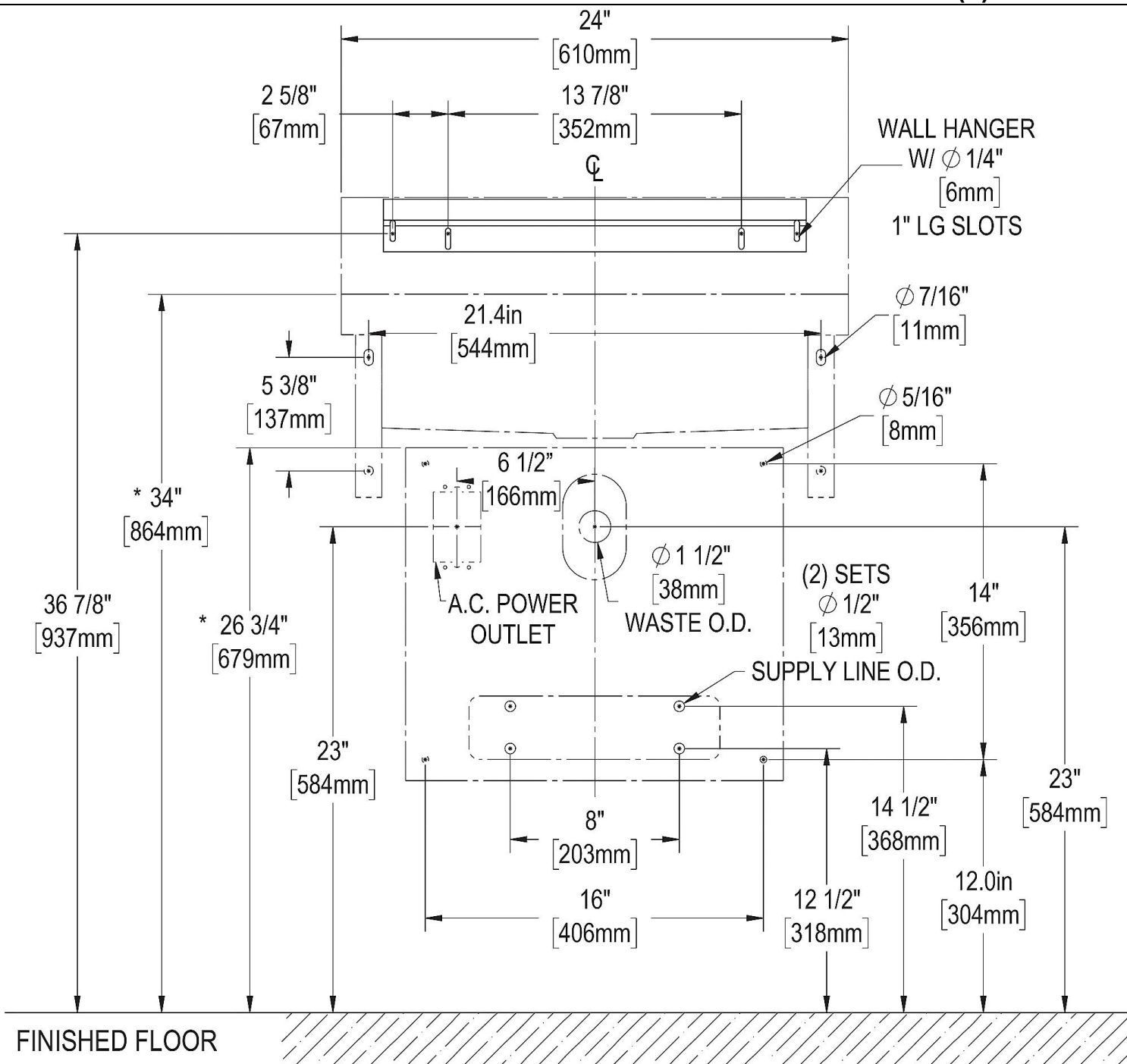

*NOTE: ALTERING THIS DIMENSION COULD CAUSE
SINK TO BECOME NON-ADA COMPLIANT

In keeping with our policy of continuing product improvement, Elkay reserves the right to change product specifications without notice. Please visit elkay.com for the most current version of Elkay product specification sheets. This specification describes an Elkay product with design, quality, and functional benefits to the user. When making a comparison of other producers' offerings, be certain these features are not overlooked.