

ELKAY®

Elkay Refrigerated Pro Filtration Bottle Filler Only series LZ8WSS & LZ8WSB Pro



Contents

1. General Information	3	6. Programming and Error Codes	13
1.1 Installation Manual	3	6.1 Instructions to Access Programming/ Menu buttons on the Control Board	14
1.2 Disclaimer	3	6.2 Programming Instructions	14
1.3 Serial Number Location	3	6.3 Pro Filtration Error Codes	16
1.4 Contact Information	3	7. Filter Maintenance	17
1.5 Notice of Changes	3	7.1 Filter status and Replacement	17
1.6 Warranty	3	7.2 Replacement Filters and Combinations	18
2. Safety	4	7.3 Instruction For Filter Setup Setting	19
2.1 General	4	7.4 Instruction For Replacing Filters	19
2.2 Safety Alert Symbol	4	8. PlumbSMART Instructions	20
2.3 Personal Safety	4	8.1 PlumbSMART Gateway Instruction Guide	20
2.4 Property Damage	5	8.2 PlumbSMART Product Registration	20
3. Tools and Supplies	5	9. Electrical Schematics and Plumbing Diagrams	22
3.1 Tools Required	5	9.1 Electrical Schematics	22
3.2 Installer Supplied Parts	5	9.2 Plumbing Diagrams	24
4. Preparation	6	9.3 Bottle Filler and Cooler Parts Diagram	27
4.1 General Information	6	10. Frequently Asked Questions (FAQ)	30
4.2 Water, Waste, and Electrical Locations	6		
5. Installation of Cooler	8		
5.1 Mounting Instructions	8		
5.2 Installation of Bottle Filler	10		

1. General Information

1.1 Installation Manual

Read all instructions carefully BEFORE starting the installation and familiarize yourself with the various parts of this product.

This manual contains step-by-step installation, adjustment, and maintenance instructions for the LZ8WSS and LZ8WSBPro series bottle filling stations. Followed carefully, these instructions will result in trouble-free installation of this Elkay Manufacturing Company (Elkay) product.

The installation of this product requires electrical and plumbing connections that use specific skills and knowledge. If you are unsure or not qualified to make these connections, consult a qualified plumber, electrician, or installer. Professional installation is suggested.

Any deviations, additions, and/or deletions from the described methods, without prior written approval of Elkay, will void the warranty covering this product.

Make sure the installation and use of this product meets all local, state, and federal plumbing and electrical codes.

Save these instructions for future reference.

⚠ WARNING



To avoid product or property damage, personal injury, or even possible death, carefully read, understand, and follow all the instructions in this Installation & Use Manual before installing this product.

Improper installation of this product could cause a dangerous situation that results in injury or death.

Do not operate power tools unless you read and understand the instructions and warnings in this and all other applicable labels or manuals. Proper use of tools and the products described in this guide is your responsibility.

Failure to follow these instructions could result in personal injuries, water damage, and other damage to floors, pipes, walls, and other portions of your building or home.

1.2 Disclaimer

The information contained in this Installation & Use Manual is given free of charge. It is based upon technical data which we believe to be reliable and is intended for use by persons having knowledge of this technical area at their own discretion and risk. Elkay assumes no responsibility for results obtained or damage incurred from the use of this material either in whole or in part by the buyer.

1.3 Serial Number Location

Please use the serial number located on the underside of the water cooler when contacting us with questions concerning the installation of this product.

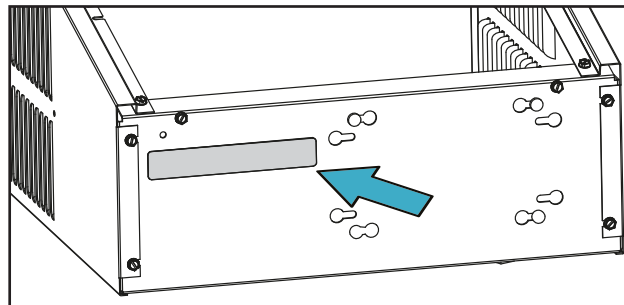

1.4 Contact Information

General Information

Elkay Manufacturing Company
1333 Butterfield Road, Suite 200
Downers Grove, IL 60515
Website: <http://www.elkay.com>

USA/Canada Customer Care

Phone: 800.260.6640
Email: CustCare@Elkay.com

International Customer Care

Phone: 630.575.4755
Email: IntlCare@Elkay.com

1.5 Notice of Changes

The information, specifications, and illustrations in this manual are based on the information that was available at the time this material was written and can change at any time. In keeping with our policy of continuing product improvement, Elkay reserves the right to change specification without notice.

All dimensions are given in inches (") and millimeters (mm).

1.6 Warranty

This product is covered by a Limited Warranty and Elkay will not be held responsible for damage of any kind in connection with the installation of the product.

Refer to the Elkay website <http://www.elkay.com/warranty> and click on drinking water products, 'Warranty for Drinking Water Products' article under the Info and Maintenance section (form 96993C).

2. Safety



Think Safety

Before performing any work, read and understand the safety instructions in this manual.

2.1 General

The Elkay Manufacturing Company (Elkay) cannot anticipate every circumstance involving a potential hazard during the installation or maintenance of this product. The warnings and instructions in this Installation Manual are, therefore, not comprehensive. If a tool, installation procedure, or work method that is not specifically recommended by Elkay is used, you must be satisfied that it is safe for yourself and others. You should also make sure that the product will not be damaged by the methods you choose.

Most work-related accidents are caused by failure to observe basic safety rules or precautions. An accident can often be avoided by recognizing potentially hazardous situations before an accident occurs. As you install and maintain this product, you must be alert to potential hazards. You should also have the necessary training, skills, and tools to perform any installation or maintenance procedure.

2.2 Safety Alert Symbol



This is the safety alert symbol. It is used to alert you to potential personal injury hazards. Obey all safety messages that follow this symbol to avoid possible injury or death.

This manual contains WARNINGS, CAUTIONS, NOTICES, SAFETY INSTRUCTIONS, and NOTES which must be followed to prevent the possibility of improper service, damage to the equipment, personal injury, or death. The following key words call the reader's attention to potential hazards.

Hazards are identified by the "Safety Alert Symbol" and followed by a signal word such as "WARNING" or "CAUTION".

2.3 Personal Safety

⚠ WARNING

These warnings indicate hazards that could result in minor or moderate injury. Follow all installation and maintenance instructions of this product.



Personal Protection

Be sure to use all personal protective equipment, such as sturdy safety glasses, work shoes, hearing protection, and gloves, whenever necessary, to ensure your own safety.



To avoid eye injury, always wear protective glasses with side shields when using power tools. Also, make sure no one else can be injured by flying particles when using power tools.



To prevent possible damage to your hearing, always wear ear protection, such as earmuffs or earplugs, when using power tools.



This product is heavy and can cause bodily injury, due to its weight or if the unit is dropped. Use two people to lift the product when unpacking the unit or installing it onto the hanger brackets.



Wear protective gloves during installation to protect against sharp edges from sheet metal components.



Lifting Hazard

- To avoid personal injury, always use these proper lifting techniques and use two people to move heavy cartons.
- Use appropriate lifting devices to move the load.
- Always use two people when lifting heavy or bulky cartons. DO NOT attempt to lift objects that are too heavy.



Power Tool Hazard

- To prevent personal injury or possible death, always follow the electrical safety recommendations of the power tool's manufacturer.
- Do not use power tools in an unsafe manner.
- Power tools should only be connected to a circuit protected by a ground-fault circuit interrupter (GFCI).
- If an extension cord is required, always use an OSHA approved extension cord.

**Shock and Electrocution Hazards**

Failure to follow these instructions could result in severe burns, significant injuries, and even death.



Water will conduct electric current to create a short circuit, resulting in injury or death.

- Never use electric power tools around water or wet floors/surfaces.
- Keep all liquids away from electrical cords and power tools.
- If an extension cord is required, always use an OSHA approved cord.
- **DO NOT** create a short circuit between a source of electricity and a liquid by being in contact with both simultaneously.



Contacting live electrical wiring with power tools or hand tools can cause serious injury or death.

- **Make sure all related circuit breakers are turned OFF.**
- **Test for live circuits or wiring inside any wall where installation of the product requires cutting into a wall.**



Prior to any maintenance, make sure the unit is unplugged and circuit breakers are turned OFF.



Prior to installation, test for live circuits or wiring inside the wall before cutting or drilling into the wall.

CAUTION

These warnings indicate hazards that could result in serious injury or death. Follow all installation and maintenance instructions of this product (unit).

**Tripping Hazard**

Personal injury can result from tripping over power cords, tools, or other installation items. **DO NOT** leave items laying around the work area.

**Cutting Hazard**

The installation of this product may require using power tools.

Keep hands away from the cutting edge of any tool used in the installation of our product.

Placing fingers in or around the cutting blades could result in serious personal injury.

**Use Proper Tools**

Always use proper tools which are in good working condition during the installation of the product. Using tools other than those listed could adversely affect the product and could result in property damage.

2.4 Property Damage**Inspect Before Cutting**

Make sure no electrical wiring or plumbing is present before cutting into a wall.

3. Tools and Supplies**3.1 Tools Required**

Tool	Used For
Tape Measure	Locating mounting brackets
Level	Mounting bracket installation
Power Drill	Installation of wall anchors or lag screws for mounting plate
Adjustable Pliers	Installation of P-trap
Adjustable Wrench	Installation of water inlet valve
Hacksaw	Trimming waste outlet pipe
Flat Blade Screwdriver	Adjustment of pressure regulator and coldness control valve
5/16" Nut Driver	Removal of mounting bracket and front panel
5/32 Allen Wrench	Removal of bottle filler front cover
Tubing Cutters	To trim excess poly tube

3.2 Installer-Supplied Parts

Description	Qty.
7/16" Wall anchors or lag screws (depending on mounting wall surface)	13
1/4" Flat washers	14
P-trap with 1-1/4" inlet (single units)	1
Quarter turn shut-off valve with angled 3/8" outlet (filtered units)	1
Flexible 3/8" tubing and 3/8" tube union fittings (filtered units)	—
1-1/4" flexible drain pipe	1

4. Preparation

4.1 General Information

1. This water cooler is designed for indoor use only and should not be installed outdoors or in a humid environment.

NOTICE A water supply pressure below 20 psi will result in decreased water flow through the unit and damage to the product. A pressure above 105 psi will also cause damage to the product.

2. Make sure the water supply pressure to the product is between 20 and 105 psi. The Pro filtered units require 40 psi minimum water pressure.
3. Use care when opening and removing the packaging to prevent damage to the product.
 - a. Inspect the product for any shipping damage and report it immediately to the location of purchase. Installation of a damaged product will void the warranty.
 - b. Confirm that all parts have been included for the proper installation of this product. Contact the location of purchase if damaged parts are found.

NOTICE Make sure no electrical wiring, potable water inlet pipes, or drain water outlet pipes are damaged during installation of the product. Damage to any of these items can cause electrical damage, fire, and/or water damage.

4. Shut off the water supply source and disconnect power to the electrical outlet being used to operate the product before starting installation.

NOTICE Mounting hardware to be supplied by customer.

4.2 Water, Waste, and Electrical Locations

This section contains general information for the required utilities for the cooler. Use the Location Drawing in each section to determine the exact location of the utilities.

1. Install water supply in accordance with local plumbing codes.
 - a. Use at least 3/8" O.D. unplated copper tube for supply line.
 - b. Pipe should extend 3" (76mm) maximum from wall.
 - c. Install a quarter-turn, installer-supplied, shutoff valve.

NOTICE Connect shutoff valve to water inlet. Do not use a piercing-type saddle valve for supply water, as this reduces water flow and clogs easier.

Note: This water cooler is designed to deliver water without contamination from materials in its internal waterways. In some buildings, electrical equipment such as telephones, computers, etc., may be grounded to water lines. The grounding may be in the building but may also occur away from the building. This grounding can introduce electrical feedback into the water cooler creating an electrolysis, which may result in a metallic taste or increased metal content in the water.

NOTICE Water cooler must be connected to the water supply using a dielectric coupling. The cooler is furnished with a non-metallic strainer which meets this requirement. The drain trap provided by the installer should be plastic to completely isolate the cooler from the building plumbing system.

2. Install a waste water drain.
 - a. Waste outlet must be minimum 1-1/4" O.D. for single units.
 - b. Pipe should extend 2" (50mm) from wall.
3. Install a grounded, electrical outlet on a dedicated circuit.
 - a. 115 volt, 60 Hz AC.
 - b. Install a dedicated 20A fused circuit.
 - c. Ground-fault circuit interrupter (GFCI) may be required. For optimal performance a 20 amp hospital grade GFCI protection device is suggested.

WARNING To prevent electrical shock, fire, or electrocution, install grounded three-prong outlet. Do not modify supplied power cord. Do not use an adapter or extension cord.

SAFETY INSTRUCTIONS To ensure proper electrical safety, the electrical supply circuit should have GFCI protection and AFCI protection, as required by federal and local electrical safety codes

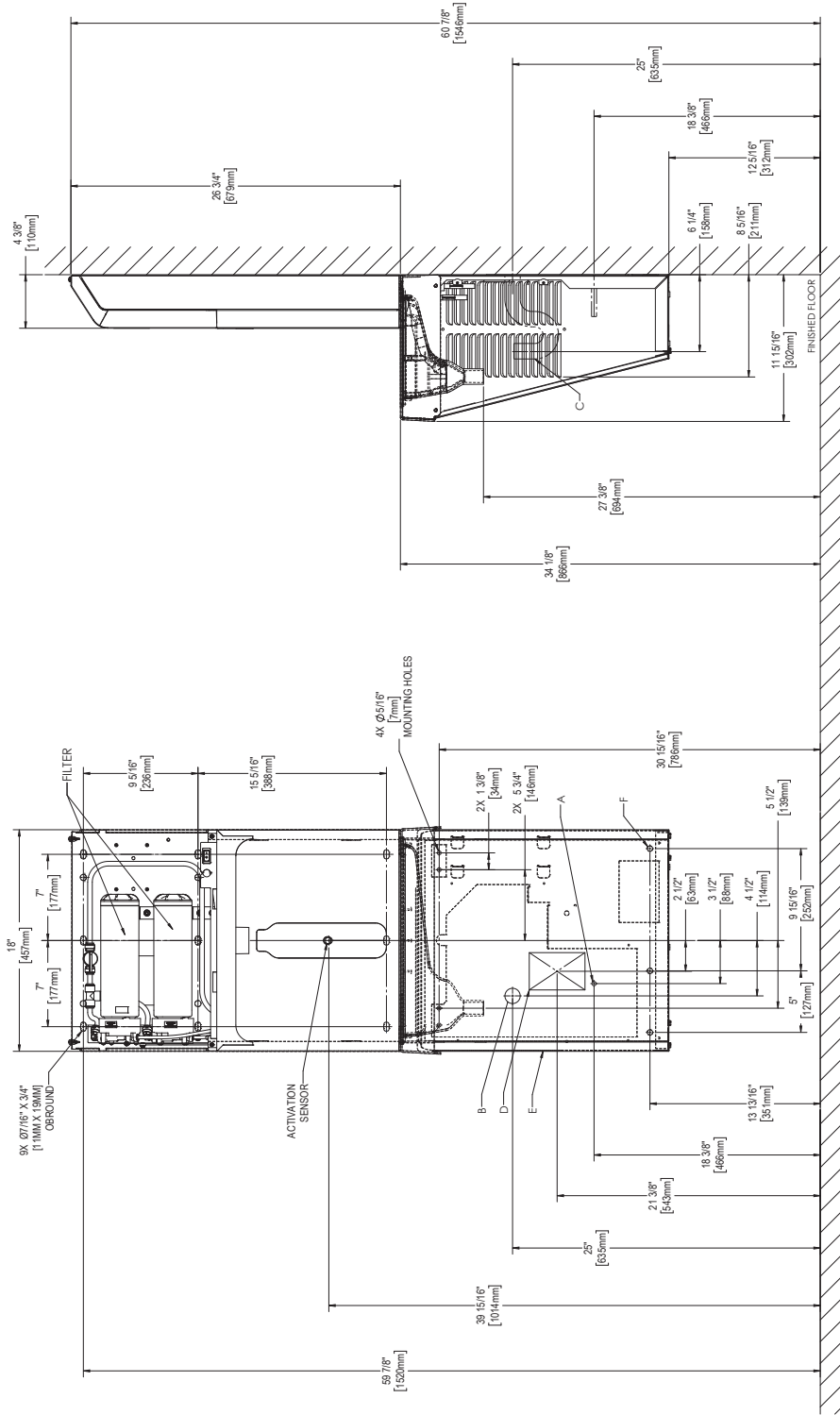

Fig. 1

REDUCE HEIGHT BY 3 INCHES FOR INSTALLATION OF CHILDREN'S ADA COOLER

- LEGEND:**
- A= RECOMMENDED WATER SUPPLY LOCATION. SHUTOFF VALVE (NOT FURNISHED) TO ACCEPT 3/8" O.D. UNPLATED COPPER TUBE. UP TO 3" (76MM) MAXIMUM OUT FROM WALL.
 - B= RECOMMENDED WASTE OUTLET LOCATION. TO ACCOMMODATE 1-1/4" NOMINAL DRAIN. DRAIN STUB 2" (51MM) OUT FROM WALL.
 - C= 1-1/4" TRAP (NOT FURNISHED).
 - D= ELECTRICAL SUPPLY (3) WIRE RECESSED BOX DUPLEX OUTLET.
 - E= ENSURE PROPER VENTILATION BY MAINTAINING 6" (152MM) MINIMUM CLEARANCE FROM CABINET LOUVERS TO WALL.
 - F= 7/16" (11MM) BOLT HOLES FOR FASTENING TO WALL.
- NOTE:** NEW INSTALLATIONS MUST USE GROUND FAULT INTERRUPTER (GFCI).

5. Installation of Cooler

5.1 Mounting Instructions

1. Remove the front cover by removing the two 5/16" hex screws on the bottom side of the cooler.

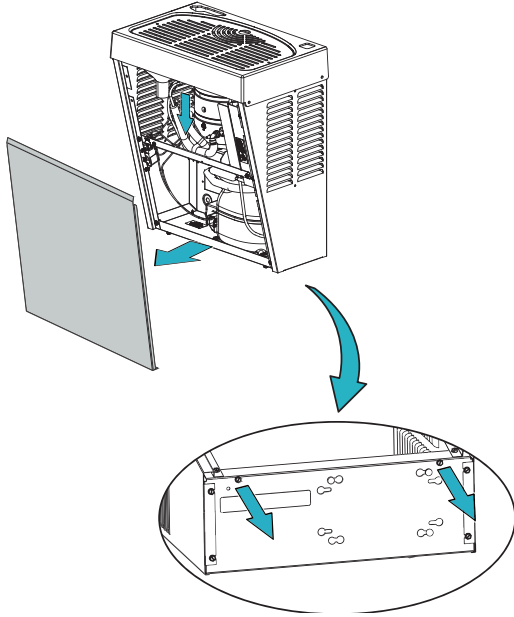
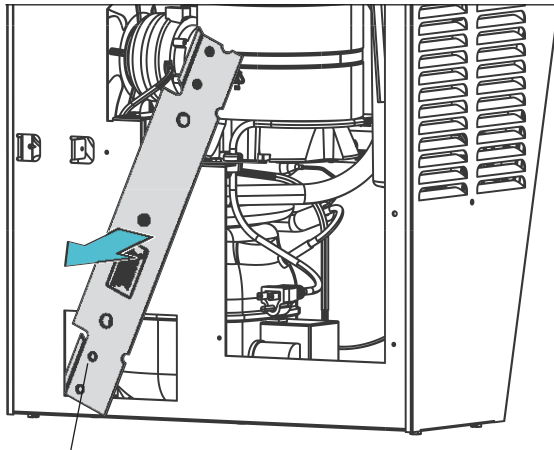

Fig. 2

2. Remove the hanger bracket.



Hanger Bracket

Fig. 3

3. Install the hanger bracket with five screws in 7/16" diameter mounting holes.
Note: Hanger bracket MUST be supported securely. Add fixture support carrier if wall will not provide adequate support.

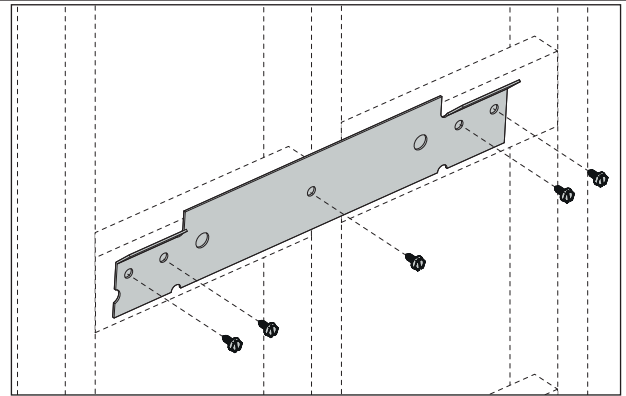

Fig. 4

4. Hang unit onto the bracket.

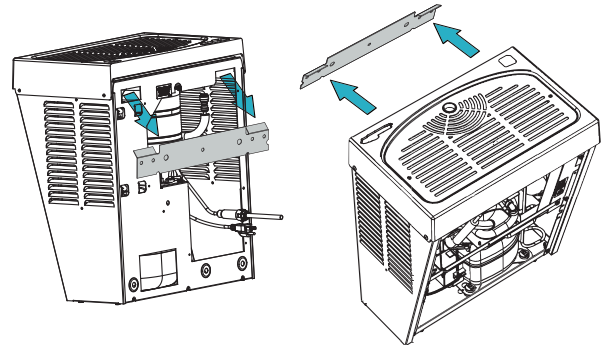

Fig. 5

5. Install the two mounting screws to attach cooler to the wall.

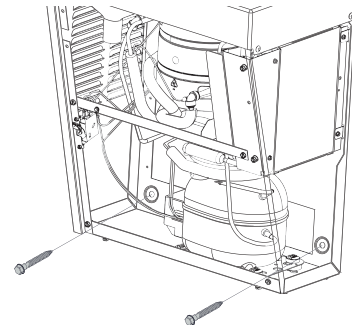

Fig. 6

6. Connect the unit water line to shut-off valve.
Note: Shut-off valve not shown (installer supplied part).
7. Connect 12VDC power supply (found in hardware kit) to barrel jack connector on cooler harness. Plug in to outlet. This will power the bottle filler tower.
8. Plug in second electrical cord to outlet. This will power the 115VAC refrigeration system.

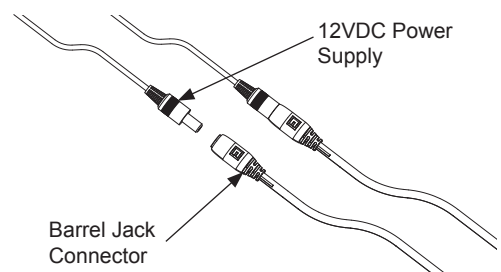
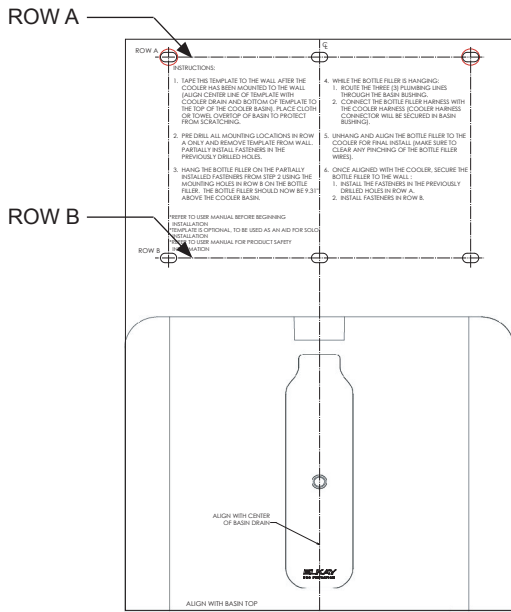

Fig. 7

5.2. Bottle Filler Installation

1. Tape the provided template to the wall. Align the template's center line with the cooler drain and its bottom edge with the top of the cooler basin. Mark and drill pilot holes for the top row (Row A) of mounting holes. Partially install fasteners (not provided) in the two outermost holes, then remove the template from the wall.

Note: The installation template is optional. If not used, refer to rough-in drawing for mounting locations.



2. Lay a soft cloth or protective layer over the basin to prevent scratching. Rest the front side of the tower on the basin face-down, with the plumbing lines facing the wall.

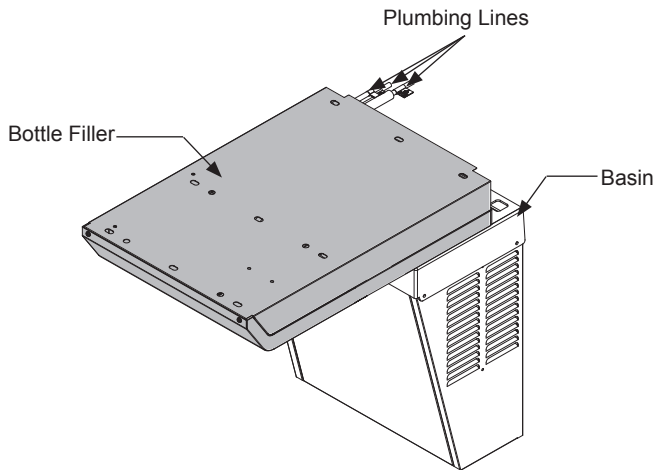

3. While the unit is resting on the basin:
 - a. Route the three (3) plumbing lines through the bushing in the basin.

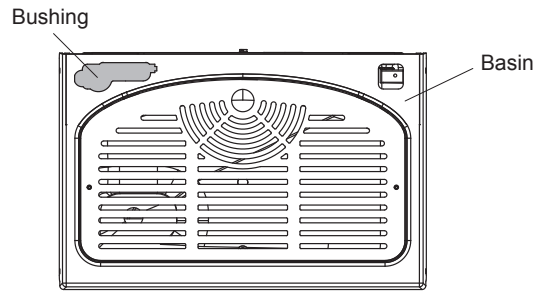

- b. Connect the bottle filler harness to the cooler harness as shown in the below figure.

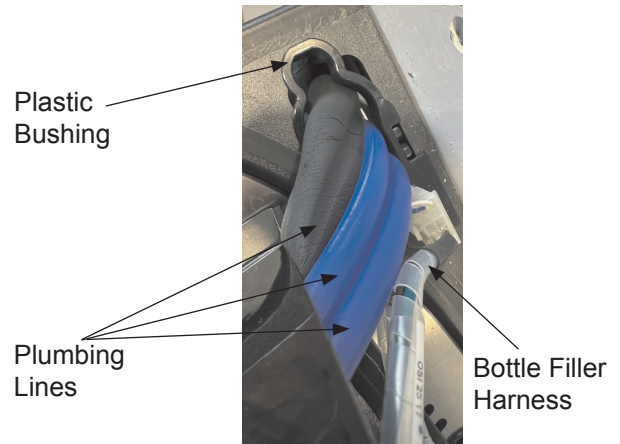

4. Keeping the bottom of the tower as close to the basin as possible, rotate the tower upward.

Note: Make sure to clear any pinching of the bottle filler wiring or plumbing while aligning the bottle filler to the cooler.

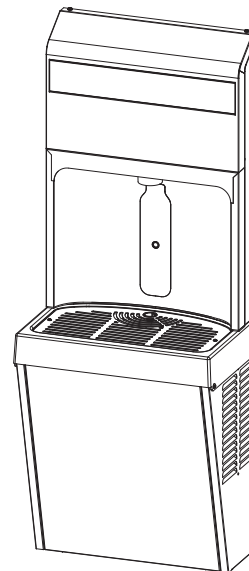

5. Remove two (2) security screws and nylon washers (T25) securing the filter access door to the bottle filler.

Note: Do not discard mounting screws and washers, they will be needed to resecure the filter access door.

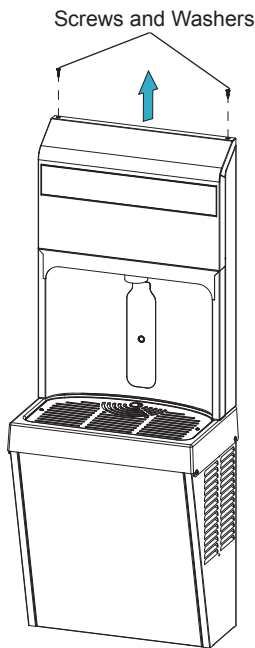

6. Open the filter access door while holding the tower against the wall.

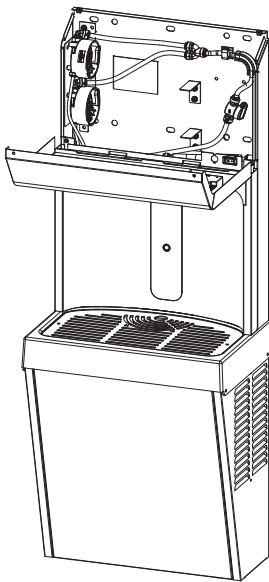

7. Secure the bottle filler to the wall using the top row of mounting holes (row A) on the bottle filler using the pre-drilled holes from step 1 and secure the bottle filler with the remaining 2 mounting holes in row A. Secure the bottle filler to the wall using the 2 remaining holes in the second row B (screws and washers not supplied).

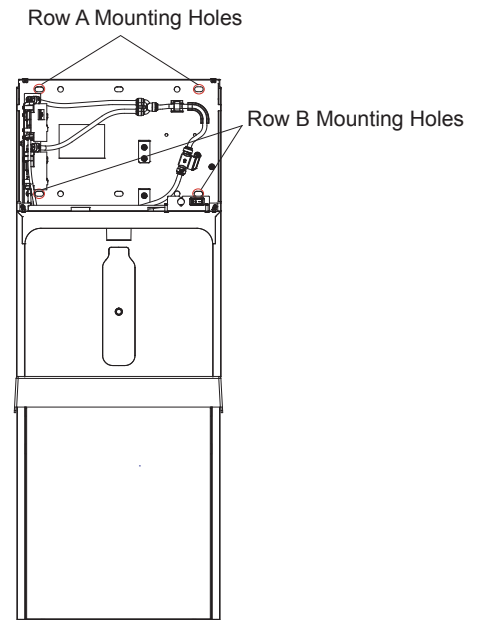

8. Before installing filters, make sure power switch is set to 'off' and water shutoff valve is closed.

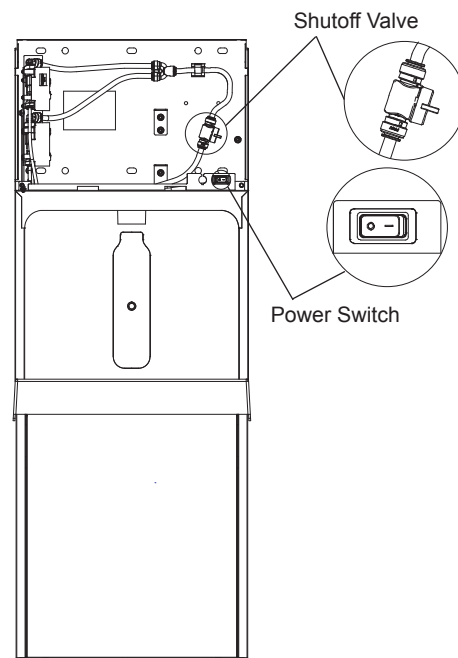

9. Remove filter from carton, remove protective cap, attach filter to filter head by firmly inserting into head and rotating filter clockwise. Refer to filter installation instructions in the filter box and refer to section 7.2 for compatible filter combinations.

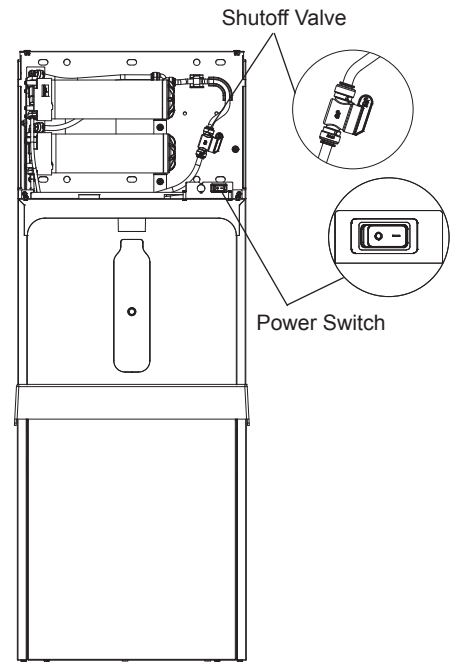
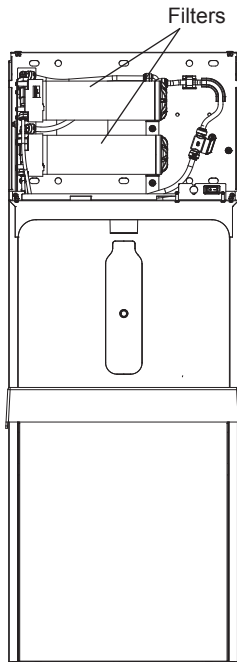

10. Connect the plumbing lines in the cooler (see labels provided on plumbing lines and plumbing diagram in section 9.2 on page 25).
- Connect the water supply to the 3/8" copper tube supplied with the installation parts kit by using the union or directly to the supply line.
 - Connect 3/8" with Armaflex to the outlet of the evaporator.
 - Connect 3/8" without Armaflex to the inlet of the evaporator.
11. Turn on main water supply and ensure that bottle filler shutoff valve is open by rotating gray lever on the water shutoff valve to counterclockwise so lever is parallel to the tubing and check for leaks.
12. Turn on electrical power by depressing the power switch moving it to the closed position.

Note: At initial start-up, the display will scroll message "AUTO-FLUSH DISABLED". If automatic filter flushing is desired now or at replacement, the setting can be turned on through the unit programming menu. Once the setting is turned ON, close menu and the unit will initiate auto flush sequence. If auto flush does not initiate, turn off power to unit and restart.

13. If the automatic filter flush feature is not desired, activate the bottle filler by placing a hand or cup in front of sensor, under the water dispenser spout. Dispense water for 3 minutes to purge air and fine carbon particles from filter.

Note: The first dispenses might have air in the line which may cause sputtering. This is normal and will resolve once all air has been purged from the line. A steady stream of water indicates that the air has been fully removed. If air becomes trapped in the inlet line or filter, micro-bubbles may form and make the water appear cloudy. These bubbles are harmless and will dissipate over time, leaving the water clear. IR sensor will time out after 20 seconds.

14. Enter programming menu and confirm current time is correct. See section 6.2 for programming menu instructions.

Setting	Default Setting
Automatic Filter Flush	Off
Display Brightness	100%
Filter Setup	Factory Set
PlumbSMART	Off
Refrigeration	On
Sensor Range	2
Set Time	Factory Set (CST Time)
UV	Factory Set

15. Once it is confirmed that there are no leaks, close and resecure the filter access door by using the two security screws and washers from step 5.

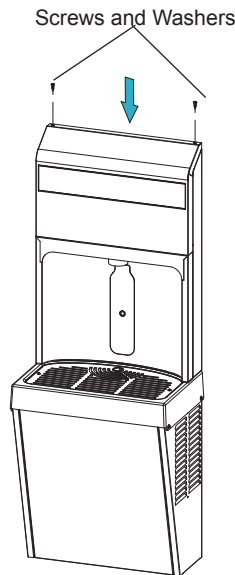

16. Verify proper dispensing from the bottle filler by placing a cup under the water dispenser spout and verify the bubbler operation by pressing the push bar on the front panel.

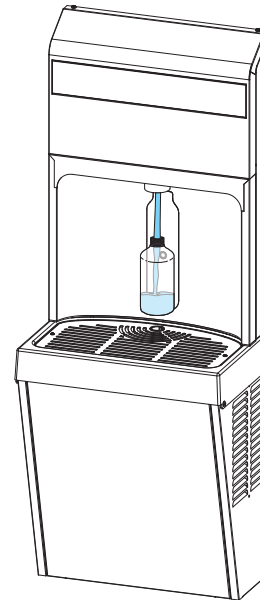

6. Programming and Error Codes

6.1 Instructions To Access Programming/Menu Buttons on the Control Board

1. Remove two (2) security screws and washers (size T25) that secure the filter access door from top and rotate the filter access door forward. The filter access door will be held in open position by the tethers.
2. The menu buttons (Up, Down, Enter) are located on the door.

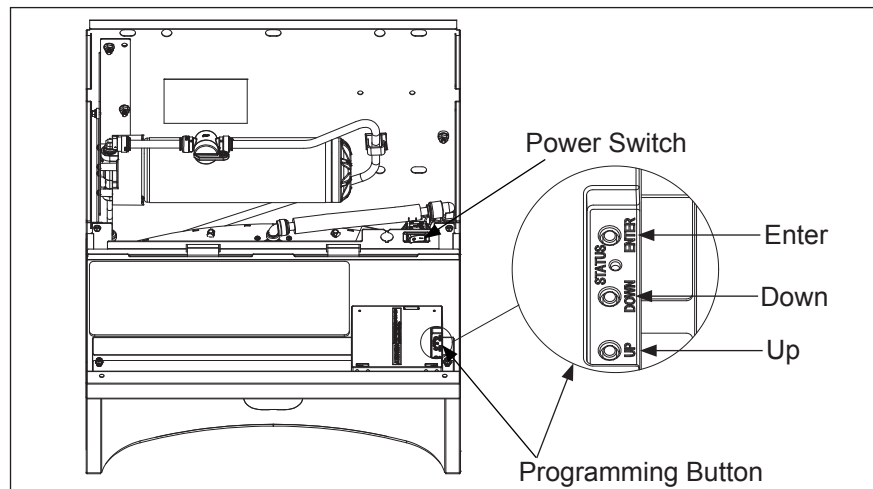

Fig. 8

6.2 Programming Instruction

Press and hold Enter button for 5 seconds to activate menu, then release.

Screen will display Errors as the first option. Use the Up and Down buttons to navigate through the menu options. If no user input is detected for 15 seconds, the menu will close and the screen will return to bottle count and filter life display.

Press the Enter button to enter a submenu. Press Up and Down to select new setting. Press Enter to save new setting or enter next submenu. To exit submenu without making changes, use Up/Down buttons to navigate to “back” and press Enter.

Top level	Sub Menu 1	Sub Menu 2	Sub Menu 3	Notes	End Action	
Errors	Lists active errors			Use Up/Down buttons to scroll through list of present errors		
	Back			Return to Main Menu		
Filter life	Filter status			Displays percentage of filter life remaining	For Prefilter configurations, individual status will be shown for each filter. For Dual Capacity configurations, a combined status will be shown for both filters.	
	Back			Return to Main Menu		
System Settings	Auto flush	On		Auto flush enabled	Enable or disable the automatic flushing of new filter(s) upon installation.	
		Off (Default)		Auto flush disabled - manual flush required after filter replacement		
		Back		Return to System Settings menu		
	Display Brightness	25%		(Dimmest)	Set display brightness	
		50%				
		75%				
		100% (Default)		(Brightest)		
		Back		Return to System Settings menu		
	Filter Setup (Factory Set)	Single	Confirm Plumbing		Set filter configuration to single filter. Press Enter to confirm that plumbing of filter system has been updated.	
		Pre Filter	Confirm Plumbing		Set filter configuration to prefilter. Press Enter to confirm that plumbing of filter system has been updated.	Sediment filter must be installed in Position 1.
		Dual Capacity	Confirm Plumbing		Set filter configuration to dual capacity. Press Enter to confirm that plumbing of filter system has been updated.	Both filters must be of the same SKU and installed at the same time.
		Back			Return to System Settings menu	
	plumbSMART	On			PlumbSMART functionality enabled.	Zurn gateway required for plumbSMART
		Off (Default)			PlumbSMART functionality disabled.	
		Back			Return to system settings menu.	
	Refrigeration	On (Default)			Refrigeration enabled	
		Off			Refrigeration disabled	
		Back			Return to System Settings menu	
	Sensor range	10			(Most sensitive)	Adjusts the sensor sensitivity. The default value is 2. Lower values require the bottle to be positioned closer to the sensor for activation.
					
1				(Least sensitive)		
Back				Return to System Settings menu		

Top level	Sub Menu 1	Sub Menu 2	Sub Menu 3	Notes	End Action	
	Set Time (Factory set to Central Time)	Set Hour	12AM		Set current hour	
					
			11PM			
			Back	Return to Set Time menu		
		Set Minute	0		Set current minute	
					
			59			
			Back	Return to Set Time menu		
		Set Year	2026		Set current year	
					
			2050			
			Back	Return to Set Time menu		
		Set Month	January		Set current month	
					
			December			
			Back	Return to Set Time menu		
		Set Day	1		Set current day	
					
			31			
			Back	Return to Set Time menu		
		Show Date-Time			Scrolls current date followed by current time. Press Enter to return to Set Time menu.	
		Back			Return to System Settings menu	
		UV (Factory Set)	On		UV functionality enabled. UV module must be connected.	
			Off		UV functionality disabled. UV module must be disconnected.	
Back			Return to System Settings menu			
Back			Return to Main Menu			
Exit				Exit Menu		

Note: Energy Saving Mode not available for LZ8WSS & LZ8WSB Pro.

6.3 Pro Filtration™ Error Codes

Error Code	Error Description	Corrective Action
BF1	Firmware error	<ul style="list-style-type: none"> Turn off power to unit for 30 seconds and restart. If the error persists, replace control board assembly.
BF3	Continuous Water Flow Warning	<ul style="list-style-type: none"> Detected continuous flow > 1 min. Turn off power to unit and restart. If the error persists, determine where flow persists and replace solenoid valve of bottle filler or cooler.
BF4	Filter Communication Error – Position #2	<ul style="list-style-type: none"> (Filter Cartridge Error) Pro Filtration filter cartridge not detected. Ensure filter is properly installed. If the error persists, replace it with new filter.
BF5	Filter Communication Error – Position #1	<ul style="list-style-type: none"> (Filter Cartridge Error) Pro Filtration filter cartridge not detected. Ensure filter is properly installed. If the error persists, replace it with new filter.
BF6	Filter Communication Error – Position #2	<ul style="list-style-type: none"> (Filter Head Error) Connection not detected to lower filter head. Ensure filter head wire is connected to wiring harness. Turn off power to unit and restart. If the error persists, replace lower filter head assembly.
BF7	Filter Communication Error – Position #1	<ul style="list-style-type: none"> (Filter Head Error) Connection not detected to upper filter head. Ensure filter head wire is connected to wiring harness. Turn off power to unit and restart. If the error persists, replace upper filter head assembly.
BF10	No Flow Warning	<ul style="list-style-type: none"> No water flow detected. Ensure incoming water to cooler and bottle filler valves are open inside the unit. If the error persists, turn off power to unit and restart.
BF11	Filter Position Warning	<ul style="list-style-type: none"> Verify sediment prefilter cartridge is installed in filter head position #1, and a contaminant filter cartridge is installed in filter head position #2.
BF12	Filter Mismatch Warning	<ul style="list-style-type: none"> Double Capacity Config: Verify a filter cartridge is installed in both filter positions #1 & #2. Filters must be the same contaminant filter type & replaced at the same time. If the error persists, replace both filters.
UV1	UV Module Warning	<ul style="list-style-type: none"> Detected UV module is over temperature or LED life has expired. Turn off power to unit for 30 seconds and restart. Confirm water is dispensing from bottle filler. If error persists, replace UV module.
UV2	UV Module Communication Error	<ul style="list-style-type: none"> No connection to UV module detected. Turn off power to unit and confirm main wire harness is connected to UV module. If error persists, replace UV module.

Note: Danger! Electrical shock hazard. Disconnect power before servicing unit.

7. Filter Maintenance

7.1 Filter Status and Replacement

The filter life meter indicates the life remaining of the contaminant filter based on time and volume. (Each segment represents about 4%).

Single Filter Configurations:

Once the filter(s) expires, a 'REPLACE FILTER' icon will appear, and the filter should be replaced immediately.

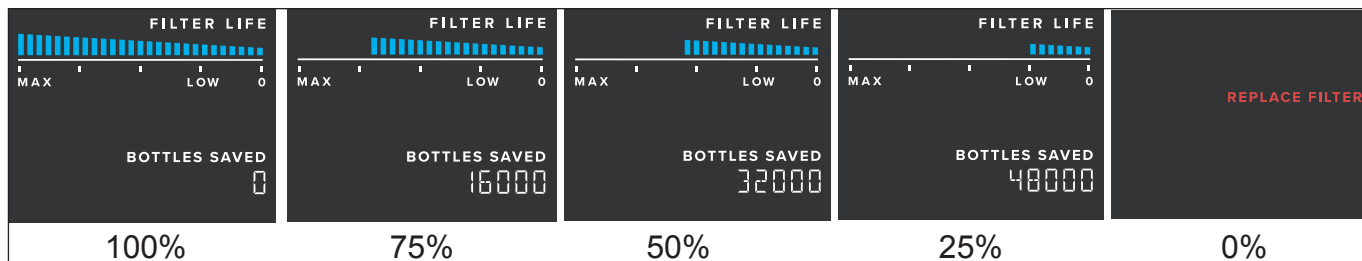

Sediment prefilter configurations:

For sediment prefilter configurations, the system tracks remaining filter life of the prefilter based on time only. If the contaminant filter expires before the sediment filter, a 'REPLACE FILTER' icon will appear and a message will scroll indicating "FILTER 2 EXPIRED". If the sediment filter expires, 'PRE FILTER 1 EXPIRED' will scroll continuously. When both filters expire the 'REPLACE FILTER' icon will appear and a message will scroll indicating "FILTERS EXPIRED". We recommend replacing both filters at once, reducing the amount of upkeep over time. Exact filter life percentage(s) can be viewed in the programming menu (navigate to Filter Life and press Enter), or remotely via plumbSMART.

Note: Sediment prefilter must be installed in Position 1 and a contaminant filter must be installed in Position 2.

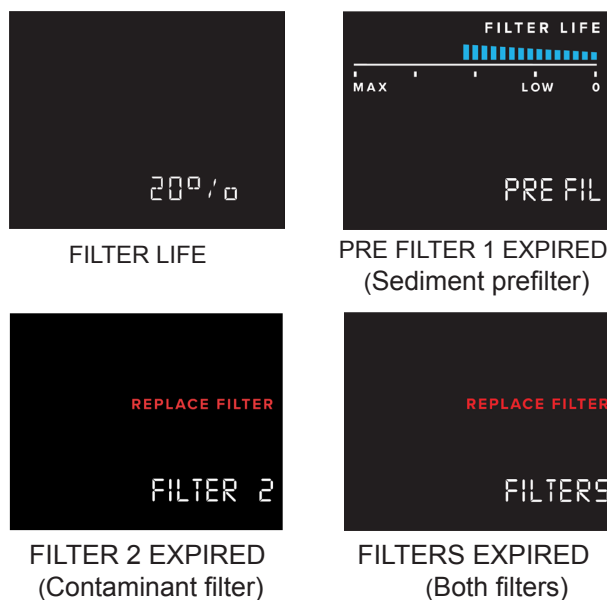

Double capacity configurations:

For double capacity configurations, the filter life meter indicates the life remaining of BOTH contaminant filters based on time and volume. The system treats the filters as one system and tracks one filter life. When the double contaminant system's filter life expires, the 'REPLACE FILTER' icon will appear and a message will scroll continuously indicating "FILTERS EXPIRED".

Note: Both filters must be of the same contaminant filter type and replaced at the same time. A filter cartridge must be installed in Position 1 and Position 2 at all times to operate properly.

Additionally, a 'CHECK SYSTEM' and 'CHECK FILTER' icon indicates immediate attention is required to maintain proper function.

Automatic Filter Flush (ensure water is on):

If filter change 'AUTO-FLUSH' is enabled, ensure that the auto-flush timer begins to count down. After the countdown expires, the system will begin an automatic filter flush procedure. Wait for auto flush procedure to complete; this will take up to 3 minutes. If auto-flush is disabled, "AUTO-FLUSH disabled" message scrolls across display.

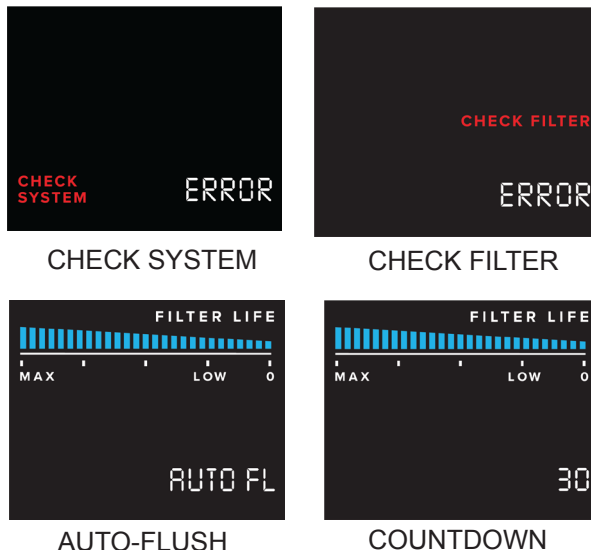

7.2 Replacement Filters and Combinations

Each filter configuration requires unique plumbing connections:

PRO FILTRATION™ FILTER PARTS LIST

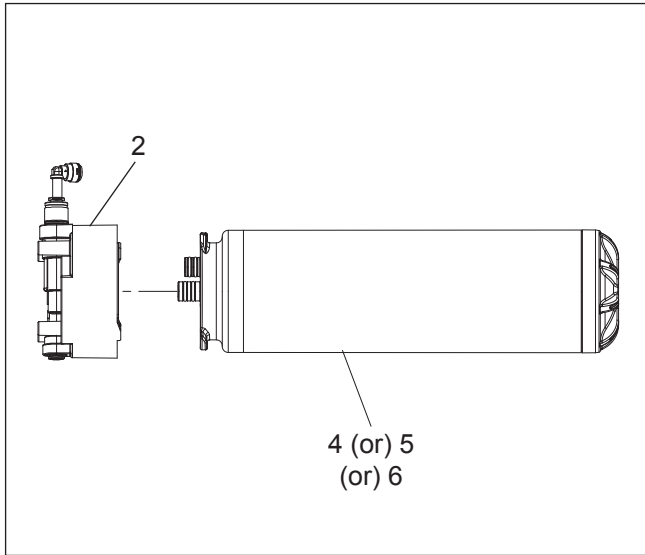

Fig. 9

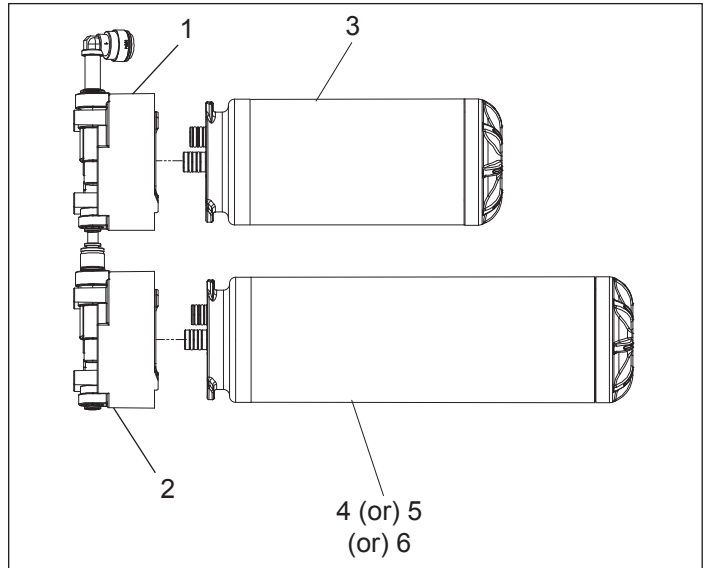

Fig. 9 A

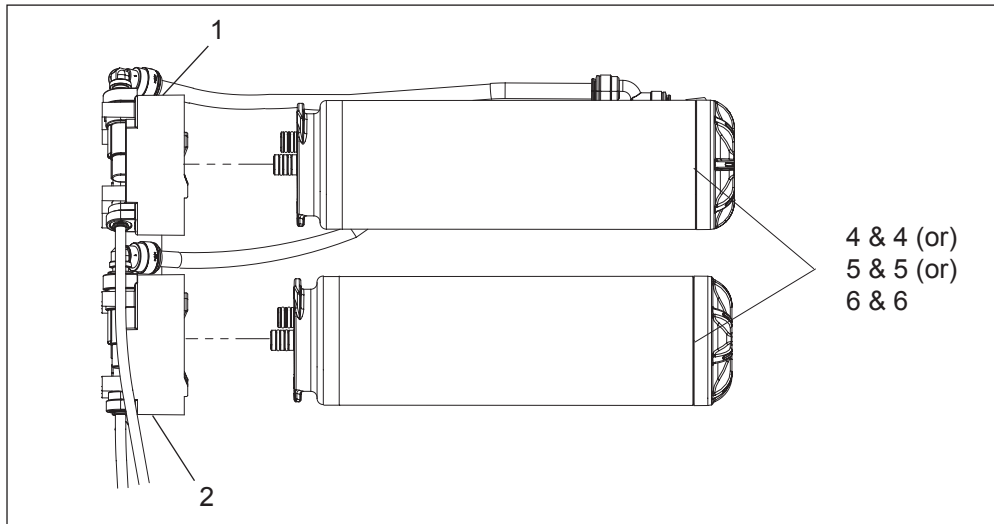

Fig. 9 B

Pro Filtration™ Filter Detail

Pro Filtration™ FILTER PARTS LIST		
ITEM NO.	PART NO.	DESCRIPTION
1	2000002438	Filter Head Assembly - Upper
2	2000001485	Filter Head Assembly - Lower
3	FSR5	Sediment Filter
4	FL6	High-Capacity Lead 6,000 gallon capacity
5	FL10	Ultra-Capacity Lead 10,000 gallon capacity
6	FLP4	Total PFAS + Lead 4,000 gallon capacity
NS	1100000031	Sediment Filter Kit – Includes Filter, Filter head, harness and mounting screws



Scan for information on where to buy and troubleshooting assistance.

7.3 Instructions For Filter Setup setting

Once the filtration system plumbing has been updated, enter the programming menu to change the Filter Setup setting on your bottle filler.

1. Press and hold "Enter" on the control board
2. Navigate to System Settings and press Enter
3. Navigate to Filter Setup and press Enter
4. Select new filter configuration
5. Once display scrolls "Confirm Plumbing," your change has been saved. Press Enter to return to previous menu.

Connection Type	Single (1 stage)	Prefilter (2 stage)	Double Capacity (1 stage)
Retrofit Kit:	N/A	1100000031	N/A
Parts Required	(1) Lower Filter Head (1) FL10/FL6/FLP4 Filter	(1) Upper Filter Head (1) Lower Filter Head (1) Stem Fitting (1) Harness 2-Filter Y Cable (1) FSR5 Filter (1) FL10/FL6/FLP4 Filter (not supplied)	(1) Upper Filter Head (1) Lower Filter Head (1) Reducing Two-Way Divider (1) Harness 2-Filter Y Cable (2) FL10/FL6/FLP4 Filter

7.4 Instructions For Replacing Filters

⚠ WARNING Turn off power when servicing filters.

1. Remove two (2) mounting screws and washers securing the filter access door to the bottle filler using Torx T25 security bit screwdriver and rotate the filter access door forward. The filter access door will be held in the open position by the tethers.
2. Enter programming menu and confirm current time is correct. See Section 6.2 for menu instructions.
3. Turn off water supply by rotating the gray lever on the water shutoff valve located in the bottle filler counterclockwise so lever is perpendicular to inlet/outlet tubing.
4. Dispense water to relieve pressure by activating bottle filler IR sensor or bubbler.
5. Turn off power to the unit using the rectangular rocker switch located above the lower right corner of door.
6. Hold a rag or towel underneath the filter before removing to catch any dripping water.
7. Rotate filter counterclockwise to disengage filter from head and remove.
8. Remove protective cap from new filter and place the cap on the used filter to seal it.
9. Engage filter to filter head by pressing filter into head and rotate filter clockwise to tighten.
10. Turn on water supply by rotating gray lever the water shutoff valve 90 degrees counterclockwise so lever is parallel to tubing.
11. Turn on electrical power to the unit using the rectangular rocker switch.
12. When power is restored, the unit will start an automatic filter flush sequence (if unit setting is on) to remove air from the system.
13. After filter flush is complete, close filter access door and reinstall mounting screws and washers.

OPERATION OF QUICK CONNECT FITTINGS

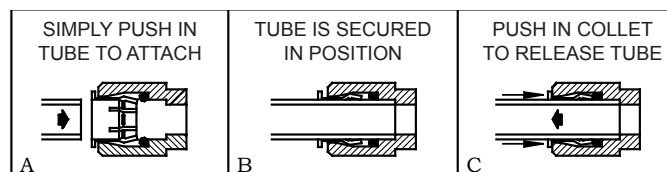

Fig. 10

8. PlumbSMART Instructions

8.1 PlumbSMART Gateway Instruction Guide

Step 1. Request Gateway:

You can request your Ethernet or LTE gateway by visiting Zurn.com/plumbSMART-gateway-request or call Zurn Customer Care at 1-844-987-6737.

Step 2. Cabling, Powering and Connecting Your Device:

1. Connect one end of the RJ45 Ethernet cable (supplied) to the gateway's Ethernet port and plug the cable's other end into the nearest wall port of the building's Ethernet network.
2. Connect the power supply to the power jack.
3. Wait for status LED to go from ON to double flash every second, the LoRa LED to turn ON solid, and the cell LED (if LTE enabled) to flash once every 3 seconds. Should take around 1-2 minutes depending on location. Your gateway is now ready to transmit data from your Zurn connected product.
4. Zurn Gateways have been set to DHCP by default. Please consult local IT support for possible additional access requirements for your network.

Step 3. Determining General Location for the Zurn Gateway:

1. Select a location central to all devices to be connected to this gateway. Ideal mapping of Gateway to connected devices will resemble a wagon wheel.
2. Place the gateway as high as possible, such as near the top of a wall.
3. Avoid obstructions. Thick walls and reflective surfaces, such as metal, weaken the signal between the gateway and other devices.
4. The LoRa antenna is an omni-directional antenna, but for best results, mount the device so the LoRa antenna is in a vertical position near the top of a wall. We recommend conducting a site survey to test the signal strength in different locations before you mount the device.

Step 4. Mounting the Zurn Gateway:

The device ships with a mounting bracket. You will also need:

- Four #6 screws with anchors
 - Screwdriver
 - Drill
1. Determine where you want to mount the device.
 2. Mark, where you want the screws to go.
 3. Drill holes for the screws and insert anchors.
 4. Place the mounting bracket and secure it with screws.
 5. Attach the device to the bracket and rotate to lock into place.

8.2 PlumbSMART Product Registration

1. Install Zurn Gateway (required and sold separately) per the gateway instructions manual, if an existing gateway is not within communication range.
2. Be sure the gateway is powered on and connected (per Gateway installation instructions) prior to installing your bottle filler. Serial number located on back of the Gateway is required to register the gateway to your tenant
3. If you have not already set up a tenant account and administrator access, request it at 844-987-6737 or zurnconnectedproducts@zurn.com
4. Log into plumbSMART.zurn.com
5. Based on the preference, Pre-register using extra PlumbSMART Registration ID Label received (Watch How To videos to get started. Located in the support section inside the portal.)

Troubleshooting Gateway:

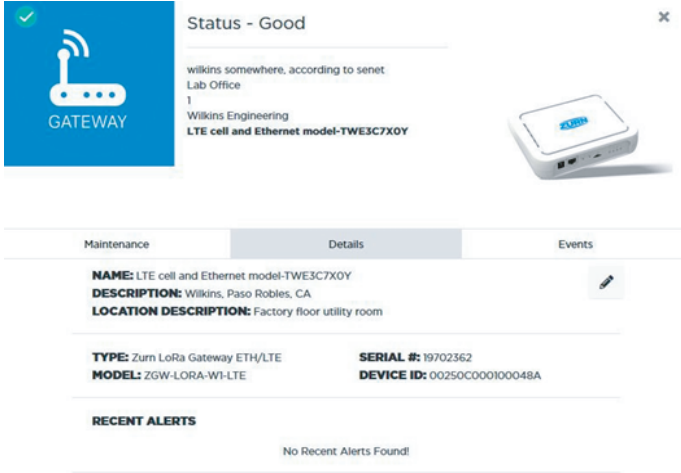
Problem	Corrective Action
<p>“Status – Good” posted in plumbSMART and bottle filler actuation event data not appearing in plumbSMART (< 2 hours) or “Device Not Communicating” warning or severe alert posted in plumbSMART for all devices (> 3 hours).</p>	<p>Step 1 Verify gateway Status LED flashes twice every 2 seconds. If LED is OFF or ON solid, power cycle the gateway and wait for no more than 5 minutes for unit to initialize and connect</p>
 <p>The screenshot shows a 'Status - Good' notification for a gateway. The gateway is a white Zurn LoRa Gateway ETH/LTE. The status is 'Good' with a green checkmark. The gateway is identified as 'LTE cell and Ethernet model-TWE3C7X0Y' located at 'Wilkins Engineering, Lab Office 1'. The gateway model is 'Zurn LoRa Gateway ETH/LTE' with serial number '19702362' and device ID '00250C000100048A'. Recent alerts are none.</p>	<p>Step 2 After initialization is finished, LORA LED should turn ON solid within an additional minute.</p> <p>Step 3 If LORA LED does not turn ON solid and ethernet cable connected, contact facility IT administrator to modify port rules to allow Zurn gateway to access the internet via local router.</p> <p>If gateway model is ETH/LTE, visually verify SIM card is installed in designated slot on the side of gateway. If unit has a SIM card, then disconnect ethernet cable and power cycle the gateway and wait for unit to initialize and connect. LORA LED should turn ON solid after initialization.</p> <p>Step 4 If problem still present, move gateway closer to LoRa monitors and/or verify gateway mounting, orientation and connections comply with requirements listed in Zurn Gateway Installation Guide.</p> <p>Contact Zurn Customer Service at 1.855.ONE.ZURN (1.855.663.9876) for assistance with additional troubleshooting steps. Contact zurnconnectedproducts@zurn.com for additional assistance.</p>

9. Electrical Schematics and Plumbing Diagrams

9.1 Electrical Schematics

Pro Filtration™ Bottle Filling Station 12VDC Wiring Diagram

LZ8WSPRO

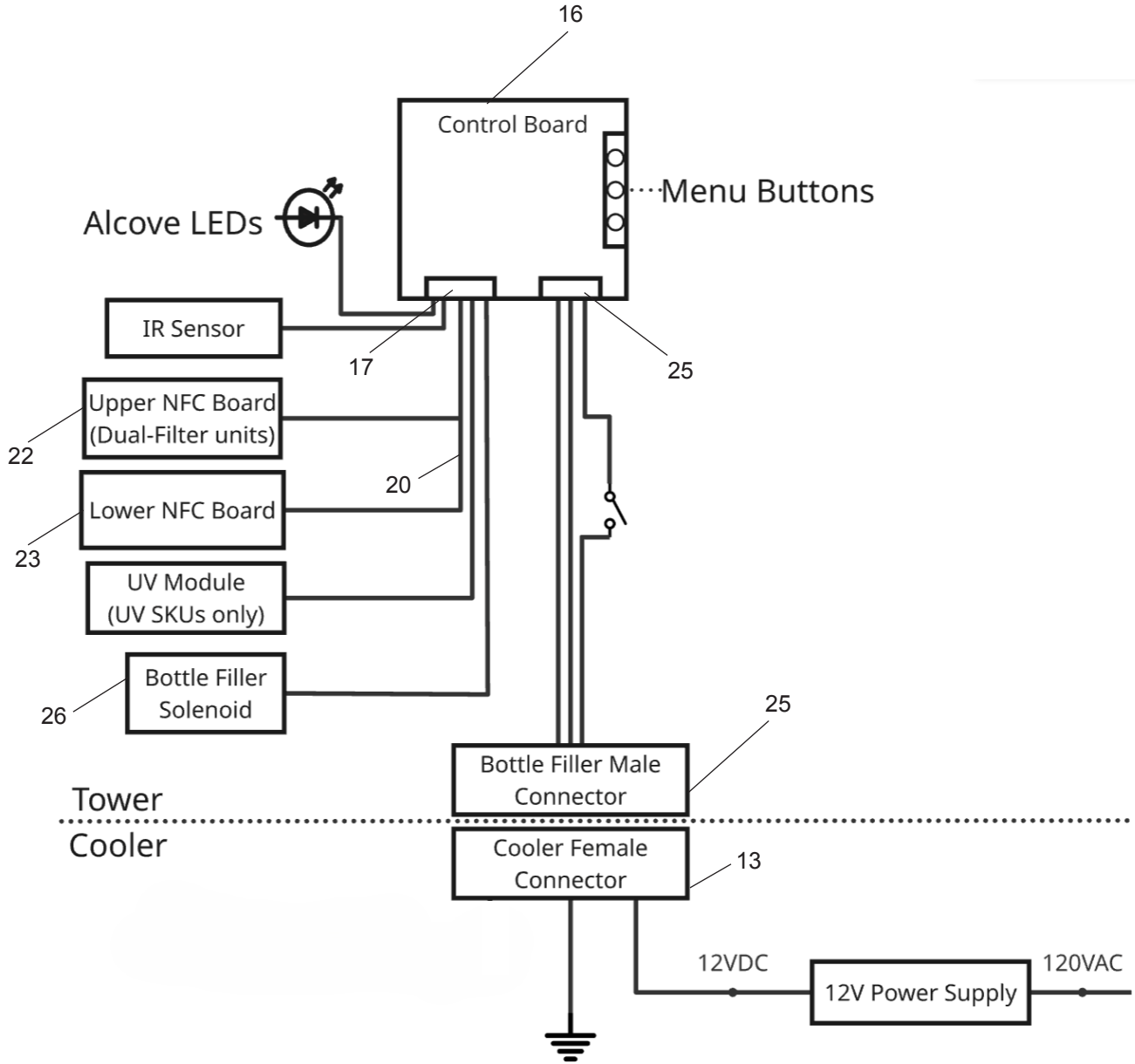

Fig. 11

Cooler Block Diagram

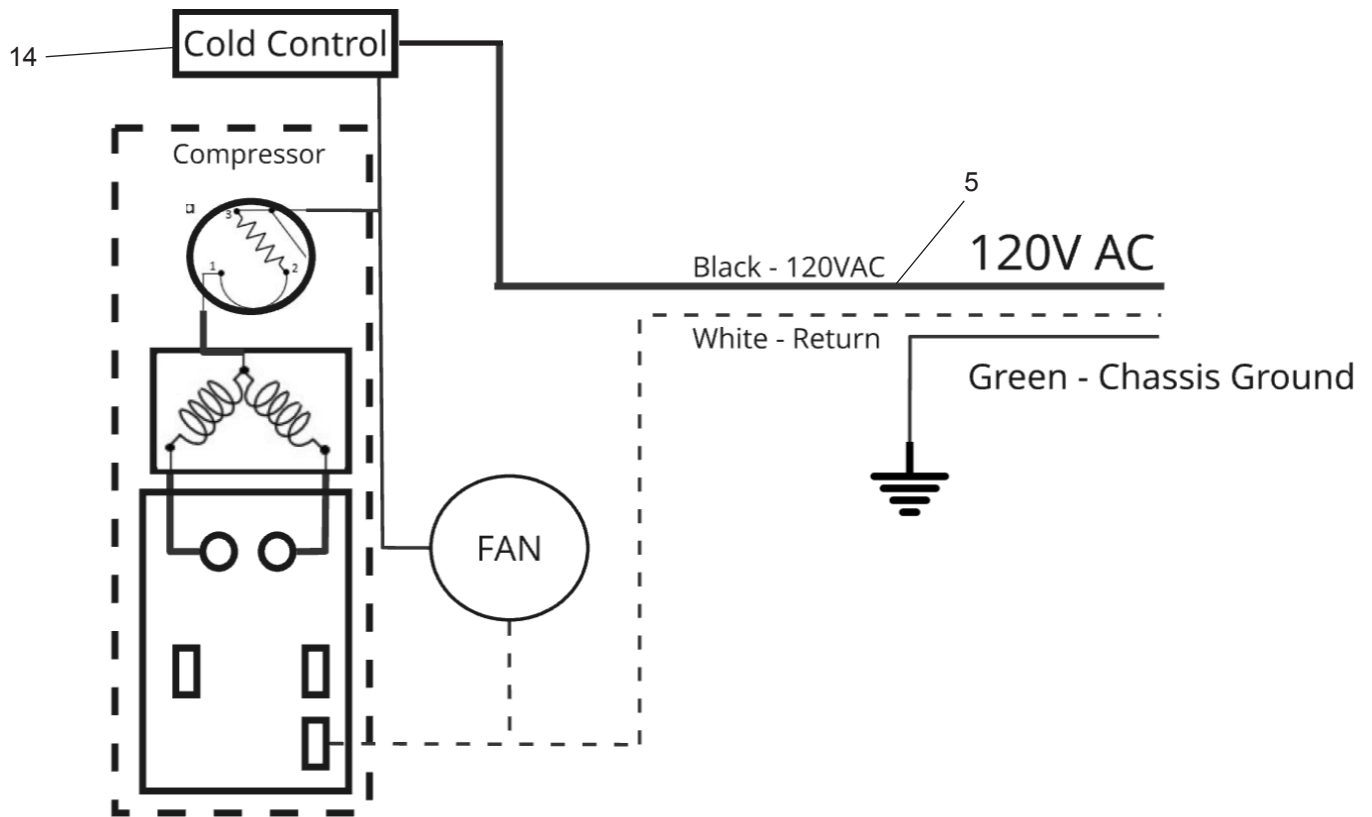

Fig. 12

WARNING

- **INGESTION HAZARD:** This product contains a button cell or coin battery.
- **DEATH** or serious injury can occur if ingested.
- A swallowed button cell or coin battery can cause **Internal Chemical Burns** in as little as **2 hours**.
- **KEEP** new and used batteries **OUT OF REACH of CHILDREN**
- **Seek immediate medical attention** if a battery is suspected to be swallowed or inserted inside any part of the body.



9.2 Plumbing Diagrams (Refer Pg. 12 step 10)

Standard Filter Configuration Plumbing Diagram

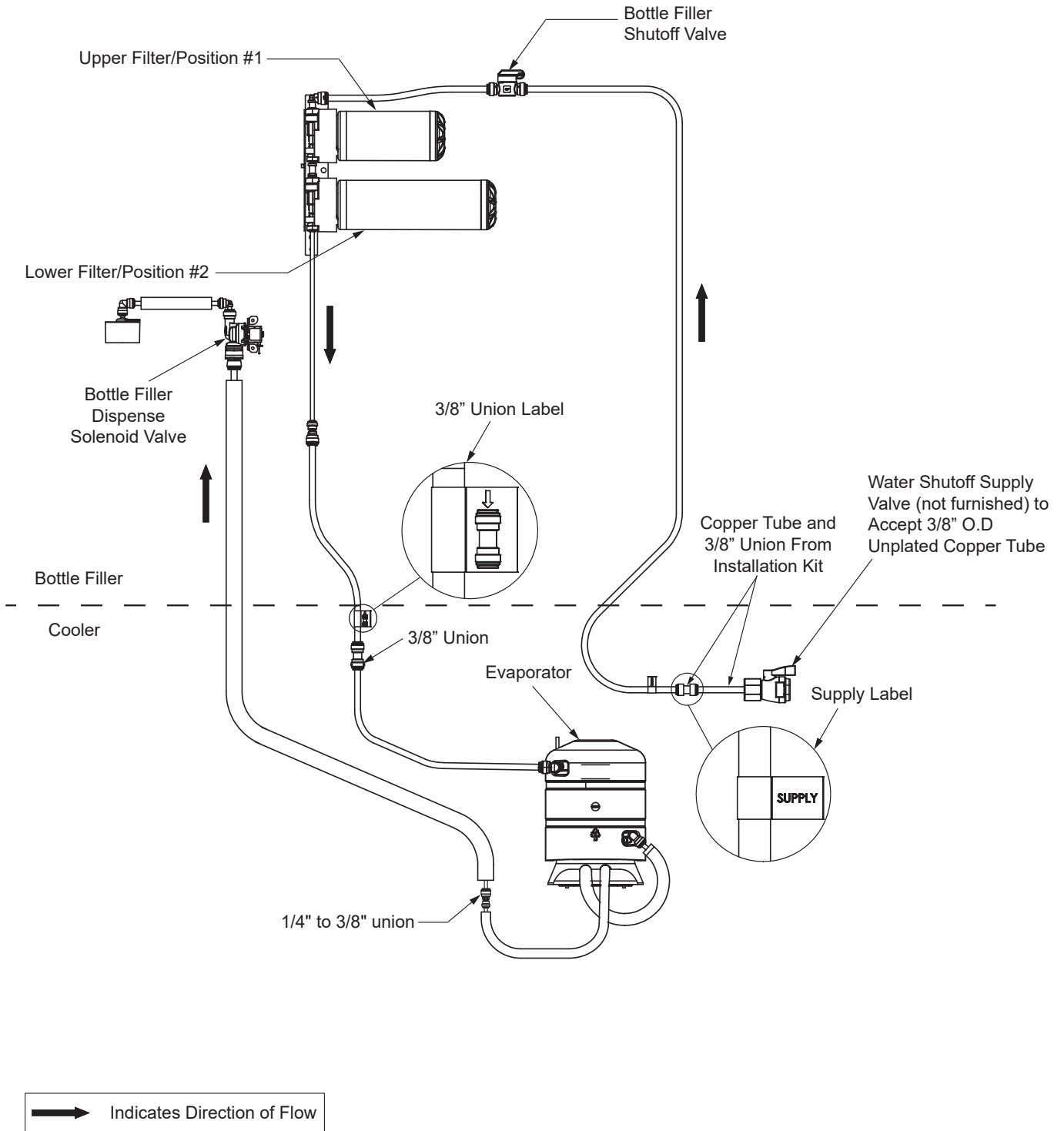

Fig. 13

Parallel Filter Configuration Plumbing Diagram

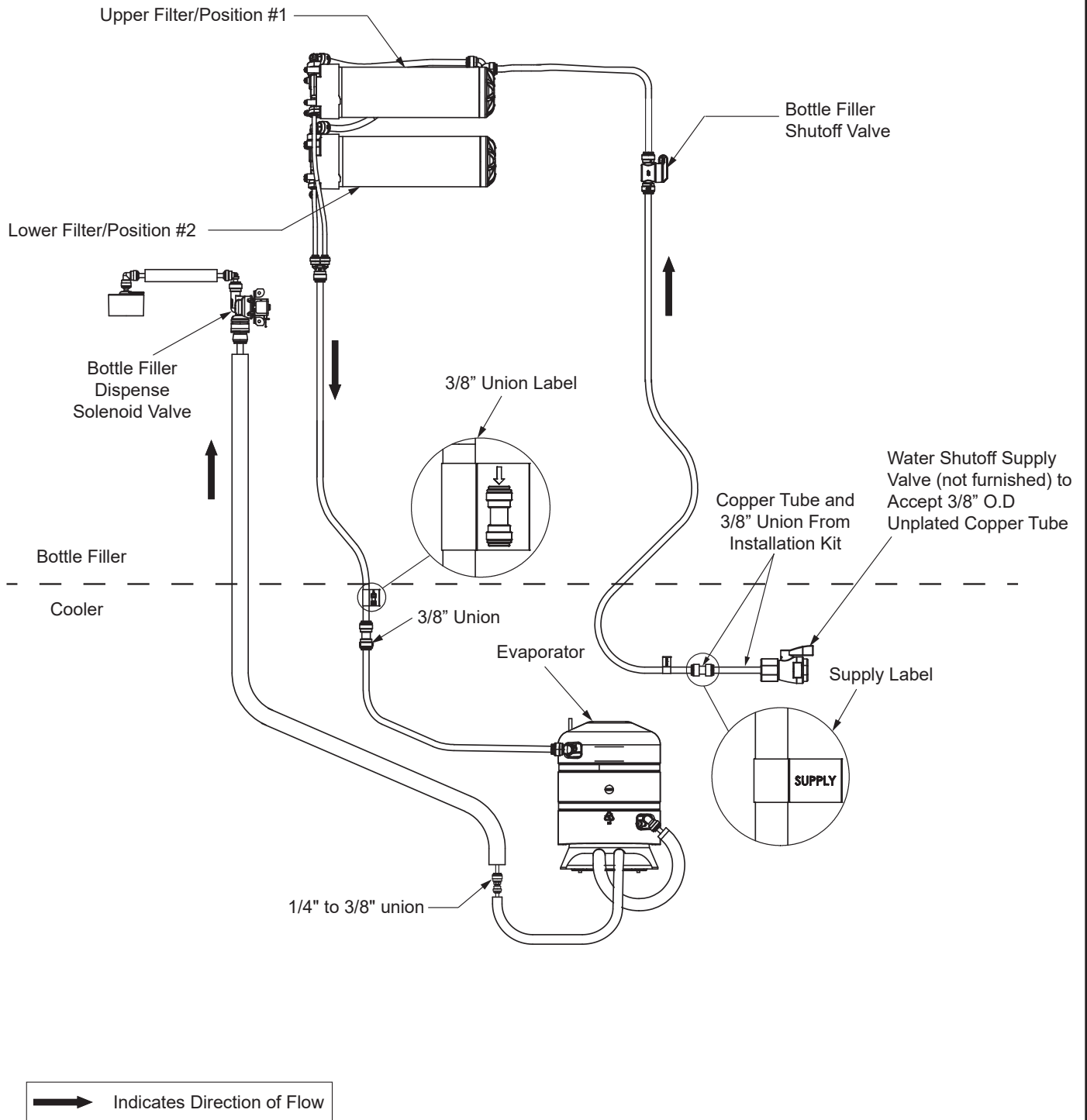

Fig. 14

UV Configuration Plumbing Diagram

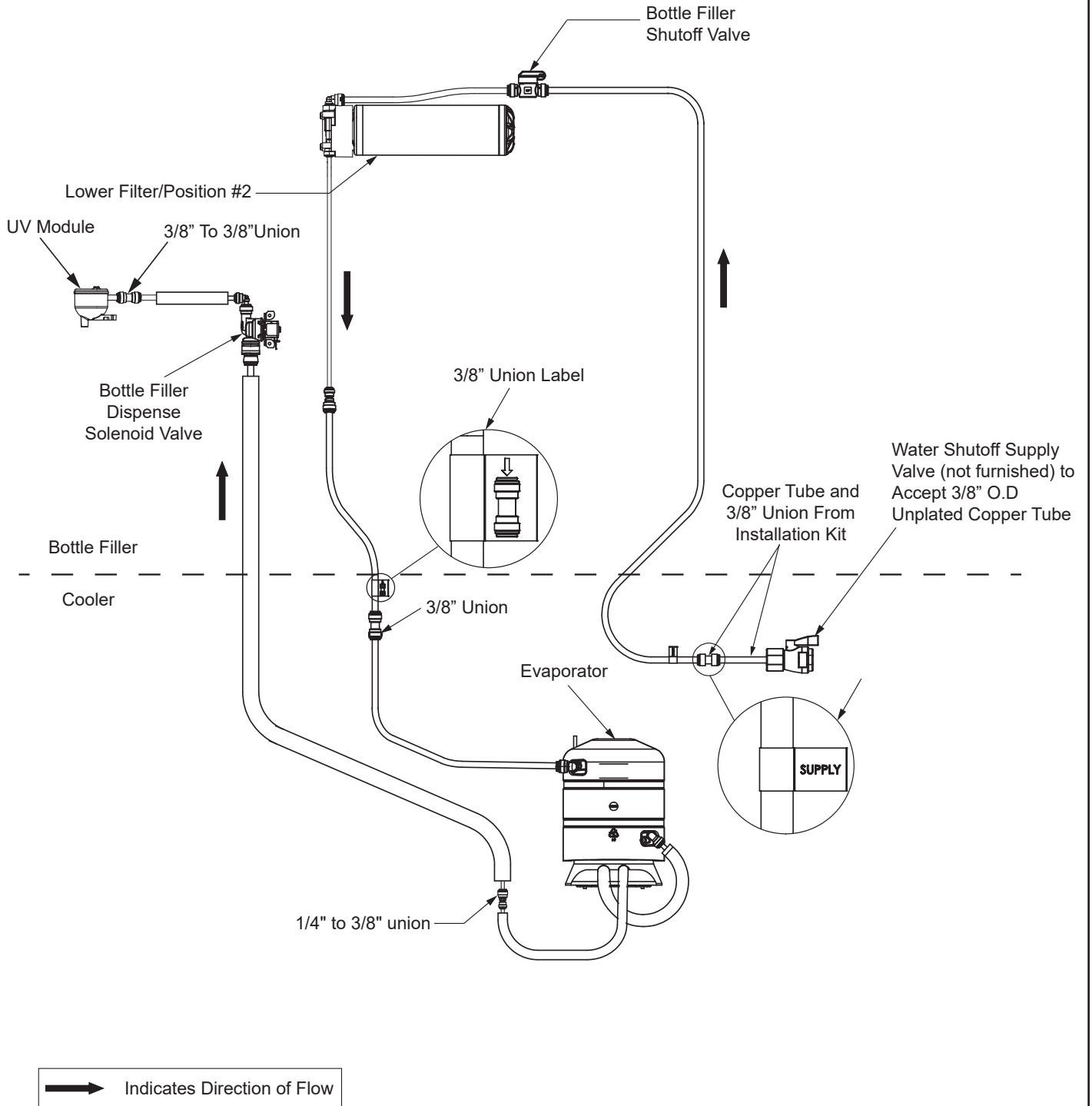

Fig. 15

9.3 Bottle Filler and Cooler Parts Diagram

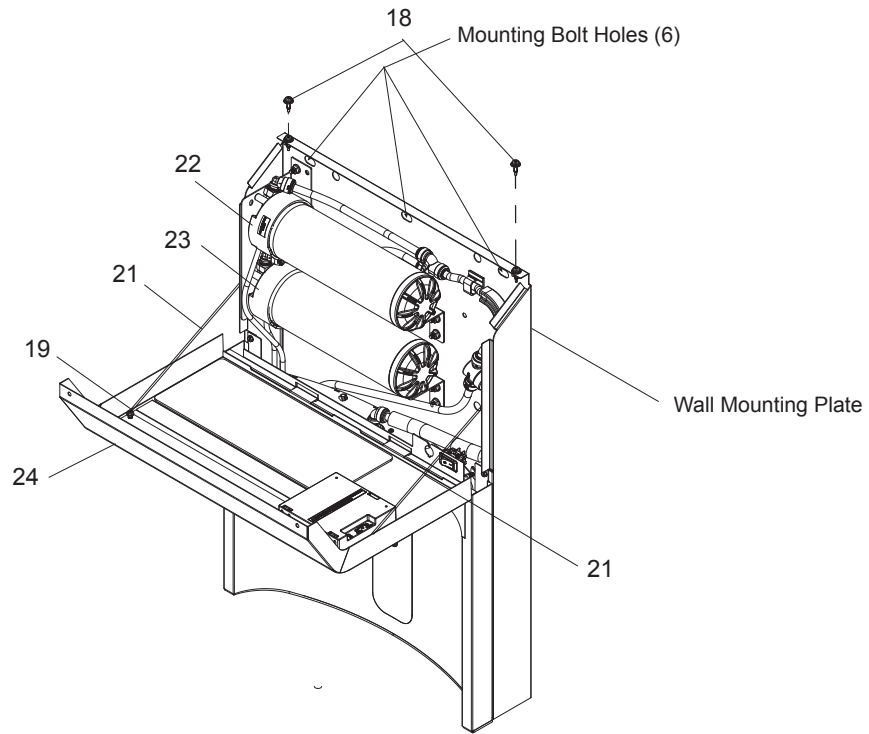

Fig. 16
BOTTLE FILLING UNIT

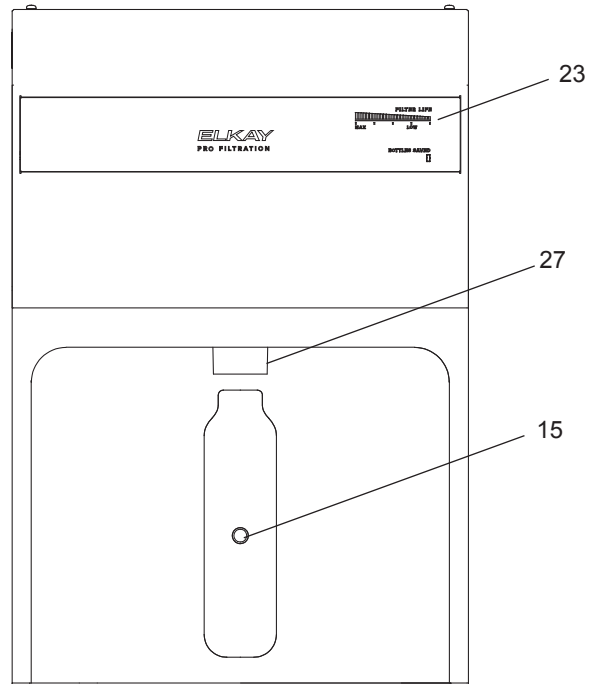

Fig. 17
BOTTLE FILLING UNIT - FRONT

Pictured is unit only without bottle filler.

Uses HFC-134A refrigerant

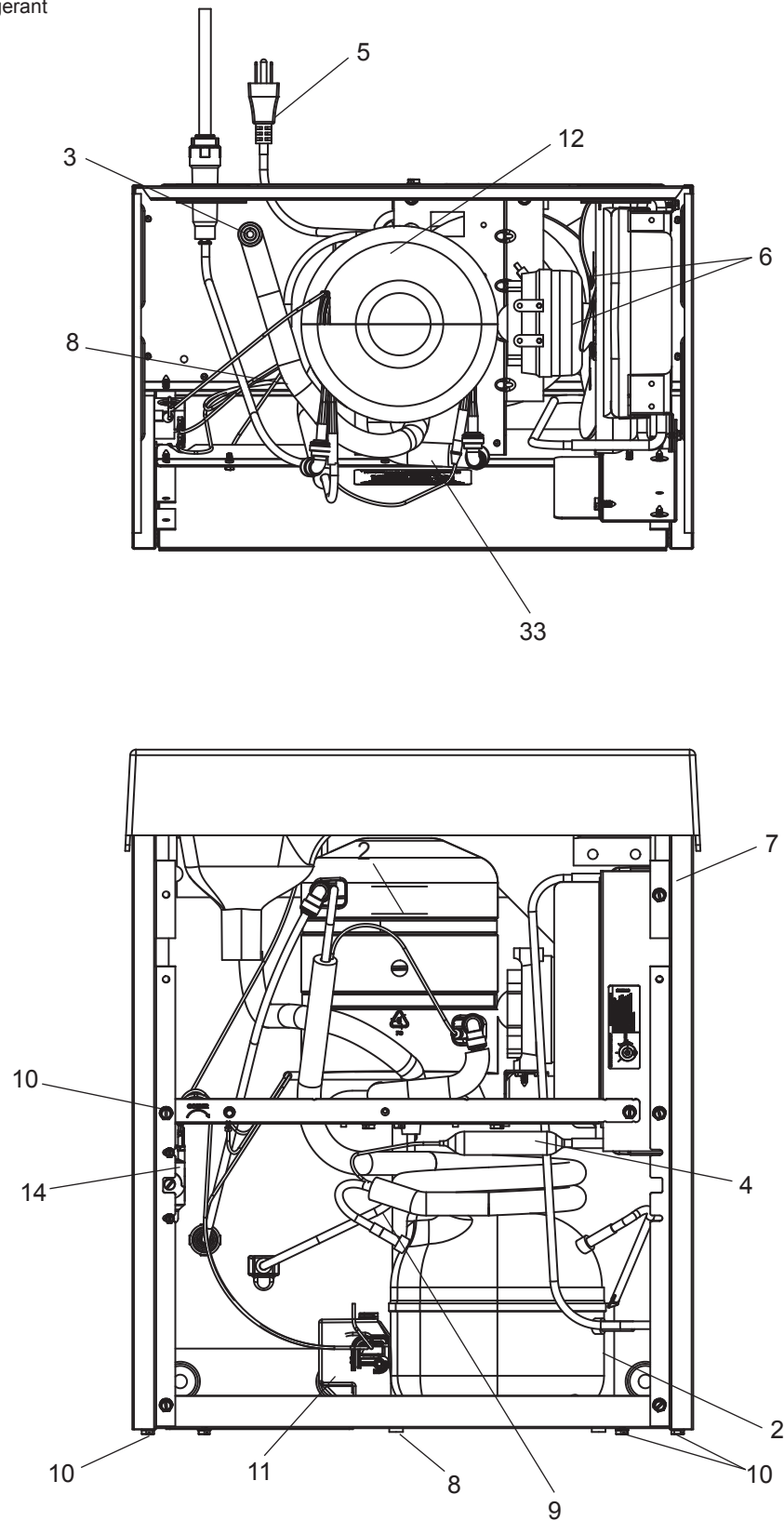

Fig. 18

REPLACEMENT PARTS LIST

ITEM NO.	PART NO.	DESCRIPTION
1	28551C	Bracket - Wall
2	36322C	Compr - Service Pak 115V EMIS70HHR
3	56092C	Tube - Poly (72")
*4	66703C	Drier
5	36208C	Power Cord
6	98775C	Kit - Fan Motor/Blade/Screws/Nut
7	98776C	Kit - Condenser/Drier/Wire Ties
8	98777C	Kit - Compr Mtg Hdwe/Grommets/Clips/Studs
9	98778C	Kit - Heatx/Drier
10	98898C	Kit - Hardware
11	000000238	Kit - 115V Electricals (Relay, Overload, Cover)
12	98724C	Kit - Evap. Replacement
13	2000003192	Harness - Cooler (PRO BFO)
14	2000001203	Kit - Cold Control
15	1000005219	Kit - IR Sensor K+
16	2000002939	12VDC Control Board with Display
17	2000002377	Harness - Bottle Filler (Upper)
18	2000001218	10-16 Security Torx Screw
19	2000001932	#6-32 x 1/4 Slotted Indented Hex Washer Head Serrated
20	2000001955	Harness 2-Filter Y-Cable
21	1100000042	Kit - Tether Replacement Kit
22	2000002438	Filter Head Module - Upper (position 1)
23	2000001485	Filter Head Module - Lower (position 2)
24	1100000044	Kit - Filter Access Door Replacement (SS/Glass)
25	2000002378	Harness - Bottle Filler (Lower)
26	2000002382	Valve - Solenoid, 12VDC
27	98546C	Kit - Aerator Replacement
NS	1100000045	Kit - Power Supply 120V AC to 12V DC 42W Replacement
NS	2000000244	Kit - UV module replacement
NS	98546C	Kit - Aerator Replacement
NS	2000000075	Kit - Basin Cover
NS	1000006133	Panel - Front Cover (Gray)
NS	28525C	Panel - Right Rear (Gray)
NS	28528C	Panel - Left Rear (Gray)
NS	2000000076	Kit - Basin Assembly (Gray)
NS	2000003238	Panel - Front Cover (Black)
NS	2000003237	Panel - Right Rear (Black)
NS	2000003239	Panel - Left Rear (Black)
NS	2000003513	Kit - Basin Assembly (Black)

NS = Not Shown ***INCLUDES RELAY & OVERLOAD. IF UNDER WARRANTY, REPLACE WITH SAME COMPRESSOR USED IN ORIGINAL ASSEMBLY.**

NOTE: All correspondence pertaining to any of the above water coolers or orders for repair parts MUST include Model No. and Serial No. of cooler, name and part number of replacement part.

10. Frequently Asked Questions (FAQ)

For FAQ questions refer to the Elkay website elkay.com

FCC COMPLIANCE STATEMENT

CAUTION: Changes or modifications not expressly approved could void your authority to use this equipment

This device complies with Part 15 of the FCC Rules. Operation is subject to the following two conditions: (1) This device may not cause harmful interference, and (2) this device must accept any interference received, including interference that may cause undesired operation.

NOTE: This equipment has been tested and found to comply with the limits for a Class B digital device, pursuant to part 15 of the FCC Rules. These limits are designed to provide reasonable protection against harmful interference in a residential installation. This equipment generates, uses and can radiate radio frequency energy and, if not installed and used in accordance with the instructions, may cause harmful interference to radio communications. However, there is no guarantee that interference will not occur in a particular installation. If this equipment does cause harmful interference to radio or television reception, which can be determined by turning the equipment off and on, the user is encouraged to try to correct the interference by one or more of the following measures:

- Reorient or relocate the receiving antenna.
- Increase the separation between the equipment and receiver.
- Connect the equipment into an outlet on a circuit different from that to which the receiver is connected.
- Consult the dealer or an experienced radio/TV technician for help.

To ensure compliance with FCC and ISED RF exposure requirements this device must be installed to provide a minimum of 20cm between the device and people.

INDUSTRY CANADA STATEMENT

This device complies with Industry Canada license-exempt RSS standard(s). Operation is subject to the following two conditions: (1) this device may not cause interference, and (2) this device must accept any interference, including interference that may cause undesired operation of the device.

Le présent appareil est conforme aux CNR d'Industrie Canada applicables aux appareils radio exempts de licence. L'exploitation est autorisée aux deux conditions suivantes : (1) l'appareil ne doit pas produire de brouillage, et (2) l'utilisateur de l'appareil doit accepter tout brouillage radioélectrique subi, même si le brouillage est susceptible d'en compromettre le fonctionnement.



2000003315

Patent zurnelkay.com/patents

FOR PARTS, CONTACT YOUR LOCAL DISTRIBUTOR OR CALL 1.800.834.4816

PRINTED IN U.S.A.

REPAIR SERVICE INFORMATION TOLL FREE NUMBER 1.800.260.6640

ELKAY MANUFACTURING COMPANY • 1333 BUTTERFIELD ROAD SUITE 200 • DOWNERS GROVE, IL 60515 USA • 630.574.8484 • www.elkay.com