



ELKAY Pharmacy Sink Maintenance Record and Parts Information

This page intentionally left blank.



ZG6922-FC1.5-TMV-1(-W2)

WALL MOUNTED SENSOR FAUCET WITH RENEWABLE HYDROPOWER

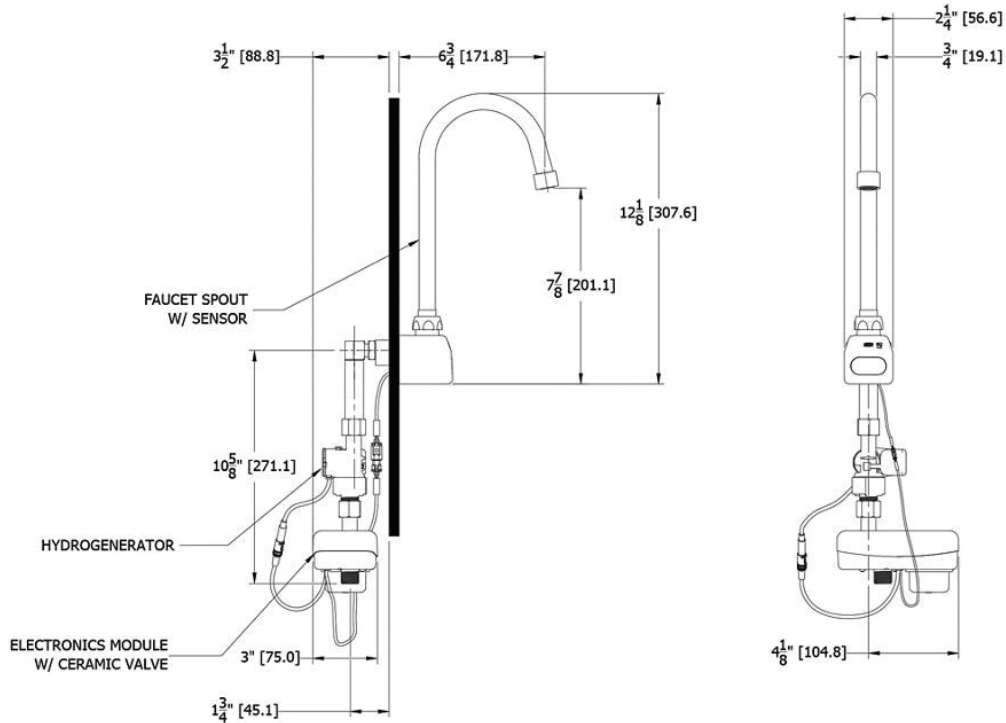

Product Specifications

Mounting Type:	Wall Mount
Special Features:	Sensor Activated Thermostatic Mixing Valve Included Hydrogenerator Power
Finish:	Chrome (CR)
Handle Type:	Sensor Operated (Hands Free)
Deck Clearance:	6-3/4"
Spout Reach:	7-7/8"
Spout Height:	12-1/8"
Hole Drillings:	1
Material:	Chrome-plated Brass
Valve Type:	Gear-driven Ceramic Cartridge
Valve Connection:	1/2" NPT Female
Flow Rate:	1.5 GPM
Voltage:	6 "AA" 1.5V Alkaline Cells Parallel for Faucet 4 "AA" 1.5V Alkaline Cells Series for plumbSMART Connected Monitor
Operating Water Pressure:	10 psi [172 kPa] (Running); 125 Psi [552 kPa] Max (Static)
Operating Temperature:	33°F to 140°F [1°C to 60°C]

Special Note: Sink kits ending with "W" include plumbSMART bluetooth-connectivity device for remote monitoring.

Warranty:

Limited Warranty information for faucet can be found [here](#)

This page intentionally left blank.

ACCESSORY GROUP EYEWASH - BACKSPASH MOUNT



Application:

Eyewash mounts on backsplash, spray head swings down from storage to operating position activating water flow. Configurations of spray heads available to minimize obstructions at sink.

Spray head assembly:

Each head has a flip-top dust cover, internal flow control and filter to remove impurities from water flow.

Valve:

1/2" IPS plug-type valve with Teflon coated O-ring seals. Swinging head from storage position to operating position opens orifice and activates water flow. Unit remains operational until head assembly is returned to storage position.

Strainer:

In-line strainer furnished with unit to protect valve and spray heads from debris in water supply.

Mounting:

Mount housing on backsplash using mounting hardware. Valve is installed in type 316 stainless steel housing.

Construction:

Polished chrome plated brass.

Supply:

1/2" NPT female inlet

Sign:

ANSI-compliant identification sign included.

Quality Assurance:

Unit is completely assembled and tested prior to shipment.

Specifications

Wall mounted "AutoFlow" swivel eye wash, backsplash mount, 1/2" IPS plug-type valve with Teflon coated O-ring seals and stainless steel enclosure. Supplied with in-line strainer to prevent debris from affecting the valve. Unit shall have (2) polypropylene 'GS Plus' spray heads with integral "flip-top" dust covers, filters and 1.8-GPM flow control orifices mounted on a chrome plated brass eyewash assembly (Specify spray head configuration). Activate valve by rotating 90° from stored position. Unit shall include ANSI compliant sign.

Performance: Unit shall be fully factory assembled and hydrostatically tested to meet or exceed ANSI Z358.1 – 2009, and come with a full 2-year warranty.

APPROVED FOR MANUFACTURING	
MODEL NO.:	JG-1800 QTY: _____
JOB NAME:	_____
TAG/ITEM:	_____
CUSTOMER:	_____
SIGNATURE:	_____

JUST MFG. COMPANY CONTINUES TO MAKE QUALITY AND FUNCTIONALITY A MARK OF THE JUST PRODUCT LINE. WE RESERVE THE RIGHT TO CHANGE PRODUCT INFORMATION WITHOUT NOTICE. DIMENSIONS MAY CHANGE AND MAY BE SUBJECT TO CHANGE WITHOUT NOTICE. NO RESPONSIBILITY IS ASSUMED FOR USE OF SUPERCEDED OR VOIDED DATA. JUST MFG. CO. SINKS ARE MADE IN THE U.S.A. WHEN COMPARING OTHER BRAND PRODUCTS, BE SURE TO COMPARE USA QUALITY ALONG WITH FEATURES AND DIMENSIONS.

JG-1800

FAUCET GROUP EYEWASH CONFIGURATION OPTIONS

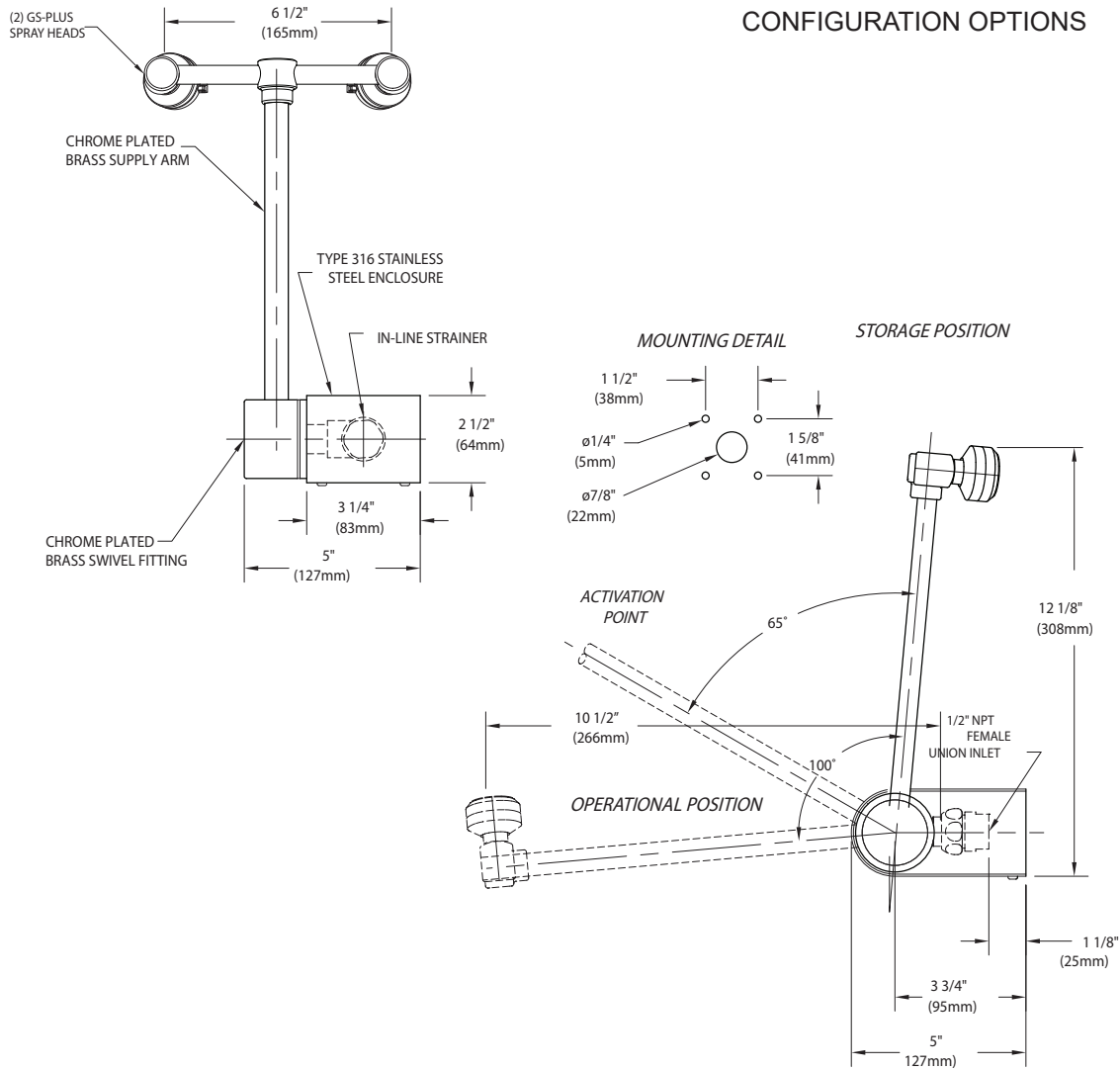

NOTES:

1. SWINGING OUTLET HEAD ASSEMBLY DOWN 100 DEGREES FROM VERTICAL TO HORIZONTAL POSITION ACTIVATES WATER FLOW.
2. EACH GS-PLUS SPRAY HEAD HAS A "FLIP-TOP" DUST COVER, INTERNAL FLOW CONTROL AND FILTER TO REMOVE IMPURITIES FROM THE WATER FLOW.
3. MOUNT HOUSING ON WALL USING ANCHORS OR OTHER HARDWARE.
4. UNIT IS FURNISHED WITH IN-LINE STRAINER TO PROTECT SPRAY HEADS AND VALVE COMPONENTS FROM DEBRIS IN WATER LINE.
5. UNIT SHOULD BE INSTALLED SO SPRAY HEADS ARE 33"-45" ABOVE FINISHED FLOOR.
6. VALVE BEGINS TO OPEN AT "ACTIVATION POINT" SHOWN ABOVE.

Sign Included





Each spray head features:

- Tough polypropylene plastic construction
- Highly visible integrated nylon dust cover
- Easily accessible 1.6 GPM (GS-Plus™) or 3.2 GPM (FS-Plus™) flow controls
- Dense (60 pore per inch) polyurethane filter
- Unique design provides a consistently soft, full spray of water across a range of working pressures from 30 to 100

Item	Part Number	Description
A	AP470-001	GS-Plus™ Spray Head (assembled)
B	AP470-002ORG-R	Dust Cover and Cap Assembly
C	470-004R	60 PPI Polyurethane Filter
D	470-005R	1.6 GPM Flow Control
E	AP470-021	FS-Plus™ Spray Head (assembled)
F	AP470-022ORG-R	Dust Cover and Cap Assembly
G	470-024R	60 PPI Polyurethane Filter
H	470-025R	3.2 GPM Flow Control

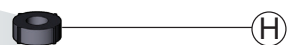
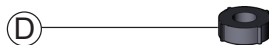
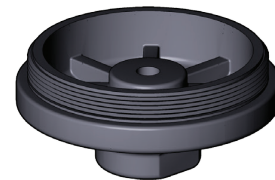
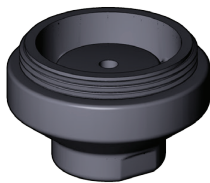
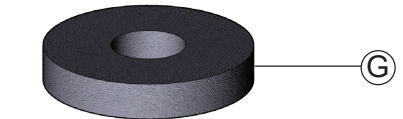
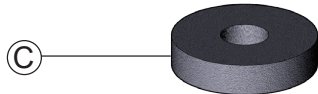
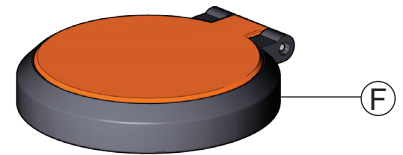
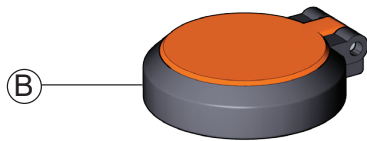
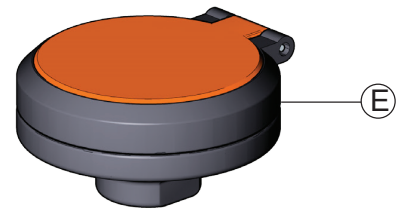
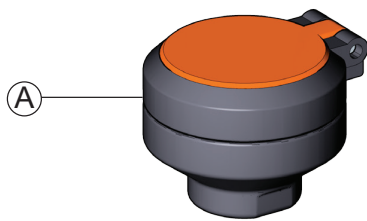

Note:

If experiencing any issues with the rotating valve assembly, please contact the factory.

IMPORTANT
In order to operate properly, the flow control must be inserted into the body concave end first.

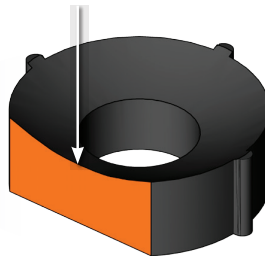



To perform weekly cleaning of the strainer:

1. Unscrew the strainer bonnet (a).
2. Inspect the o-ring (b) for damage. Replace if needed.
3. Remove cylindrical screen (c) and rinse under clean water. Gently rub the screen until all debris has been removed.
4. Carefully reinsert screen into the counterbore within the strainer body (should fit snugly).
5. Replace strainer bonnet and test for proper operation of strainer and eyewash.

Important:

All emergency equipment must be inspected and tested at least weekly to ensure proper operation. On units equipped with an in-line strainer, weekly inspection should also include checking the strainer for accumulation of debris or foreign matter. Such debris can impair the flow of water through the strainer and prevent the eyewash from functioning properly.

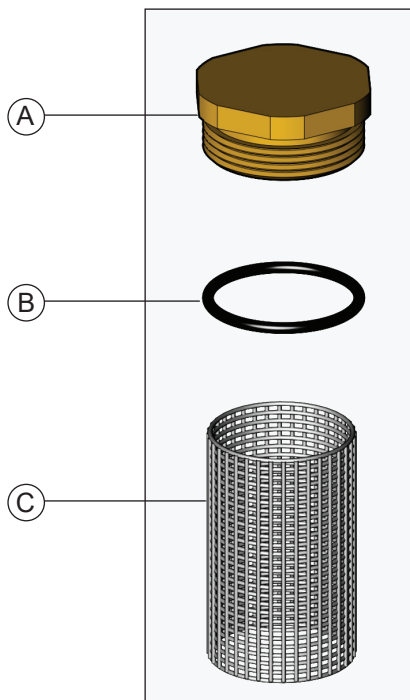

RK400-013
Repair Kit for Inline
Strainer consisting of
Bonnet, O-Ring and
50 Mesh Cylindrical Screen

AP400-013
In-Line Strainer Assembly

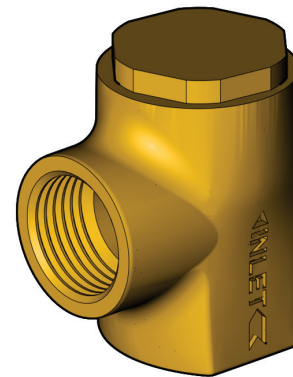

FITTINGS GROUP
CLASSROOM SINK

FAUCET LEDGE - LEFT / BUBBLER LEDGE- RIGHT



- Solid bimetal thermostat directly linked to valve porting to control the intake of hot and cold water and compensate for supply temperature and pressure fluctuations. Highly responsive and cannot be damaged by extremes in temperature.
- Thermostatic Mixing Valve can be set to the current temperature for the application.
- Locking temperature regulator to prevent accidental movement set for 85°F (29°C).
- Mixing valve will close down on failure of cold water failure.
- Mixing valve with special internal cold water bypass capable of a minimum of 4 GPM (15 l.min) @ 30 PSI (2.1 Bare) upon failure of hot water supply.
- Adjustable high temperature limit stop o set for 90°F (32°C).
- Integral wall support.
- Full 1/2" top or bottom inlets and 1/2" top outlet.
- Rough bronze finish.
- Dial thermometer (range 0 to 140oF, -10 to 60oC).
- Angle check stops on inlets.
- Compliance.....ANSI Z358.1
- Maximum supply temperature 180oF (82oC).
- Maximum supply pressure 125 PSI (8.6 Bar).

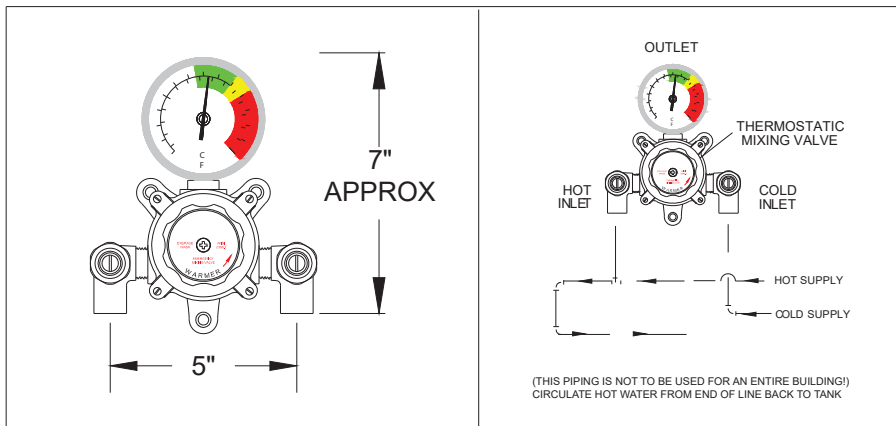

WARNING: This product can expose you to chemicals including lead which is know to the State of California to cause cancer. For more information, go to www.P65Warnings.Ca.gov

CAUTION! It may be necessary to recirculate the tempered water to the eye/face wash should the piping be exposed to excessive hot or cold conditions.

*NOTE: A limit stop, set for 90°F (32°C), is simply a mechanical setting to prevent excessive handle rotation. If incoming water is hotter than 135°F (57°C), the temperature of the factory test, the valve when turned to full HOT may deliver water in excess of 90°F (32°C) and the limit stop **MUST BE RESET BY THE INSTALLER**

CAUTION! All thermostatic mixing water mixing valves have limitations. They will NOT provide the desired accuracy outside of their flow capacity range. Consult the Flow Capacity Chart and **DO NOT OVERSIZE**. Minimum flow must be no less than as indicated.

JUST MFG. COMPANY CONTINUES TO MAKE QUALITY AND FUNCTIONALITY A MARK OF THE JUST PRODUCT LINE. WE RESERVE THE RIGHT TO CHANGE PRODUCT INFORMATION WITHOUT NOTICE. DIMENSIONS MAY CHANGE AND MAY BE SUBJECT TO CHANGE WITHOUT NOTICE. NO RESPONSIBILITY IS ASSUMED FOR USE OF SUPERCEDED OR VOIDED DATA. JUST MFG. CO. SINKS ARE MADE IN THE U.S.A. WHEN COMPARING OTHER BRAND PRODUCTS, BE SURE TO COMPARE USA QUALITY ALONG WITH FEATURES AND DIMENSIONS.

This page intentionally left blank.

INSTALLATION SETUP AND OPERATING INSTRUCTIONS
EMERGENCY MIXING VALVE SYSTEM

TA-300, TA-300-LF, TA-350, TA-350-LF

IMPORTANT! Provide valve serial number (located on valve body) when ordering parts!!
Compliance.....ANSI Z 358-1



WARNING: This product can expose you to chemicals including lead, which is known to the State of California to cause cancer. For more information, go to www.P65Warnings.Ca.gov

TA-300, TA-300-LF

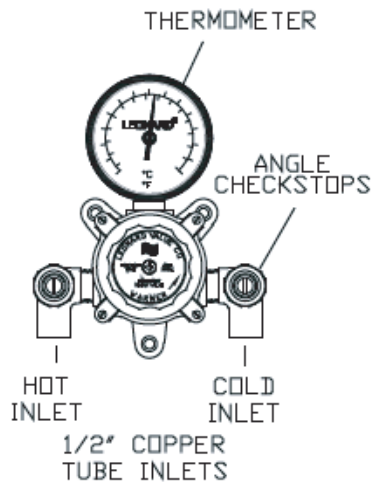

TA-350

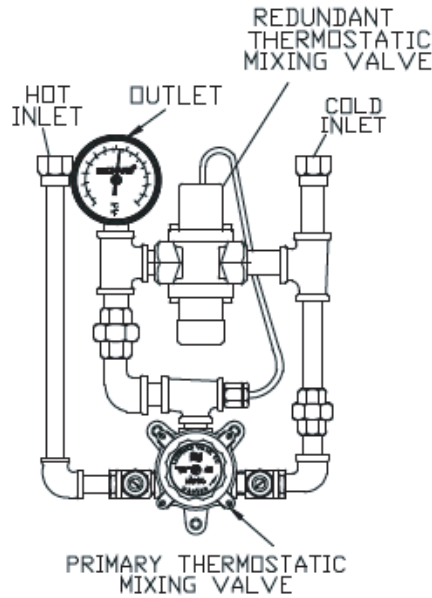

TA-350-LF

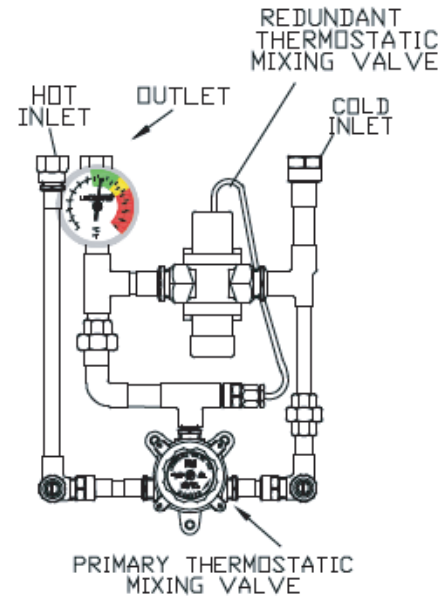

<ol style="list-style-type: none"> 1. Valve should be installed at a location where it can easily be cleaned, adjusted or repaired. 2. The inlets are clearly marked on the valve body casting. Connect the hot water into the inlet marked "HOT" and cold water into the inlet marked "COLD." 	<ol style="list-style-type: none"> 3. The checkstops furnished must be installed on both supply lines as shown above. 4. Use solder or pipe cement sparingly. Supply pipes should be flushed before the valve is connected. Flush outlet pipe and valve as soon as it is connected. <p>Maximum Operating Pressure 125PSI (860 KPA) for Hot and Cold Water.</p>
--	---

NOTE: It may be necessary to recirculate the tempered water to the face/eyewash should the piping be exposed to excessive hot or cold conditions. Consult factory for proper piping.

CAUTION

IMPORTANT! These systems are designed to provide mixed water from 60 to 90°F (15 to 32°C) for eye/face wash applications only. Call Leonard for systems designed to operate at temperatures outside of this range.

REMEMBER! THIS IS A CONTROL SYSTEM WHICH MUST BE CLEANED AND MAINTAINED ON A REGULAR BASIS (SEE MAINTENANCE GUIDE AND RECORD MGR-1001).

1360 Elmwood Avenue, Cranston, RI 02910 USA
Phone: 401.461.1200 Fax: 401.941.5310
Email: info@leonardvalve.com
Web Site: <http://www.leonardvalve.com>

ADJUSTMENT AND SERVICE

Leonard Type TA Thermostatic Water Mixing Valves are simple in design and may be easily cleaned, adjusted and repaired. If the installation is accessible, servicing may be completed without disconnecting the valve.

NOTE: Thermostatic Water Mixing Valves are REGULATING mechanisms, which must be regularly maintained to provide best performance. Frequency of cleaning depends on quality of local water conditions and usage. (See Maintenance Guide and Record MGR-1000 and ANSI Z358.1).

TO RESET ADJUSTABLE HIGH TEMPERATURE LIMIT STOP:

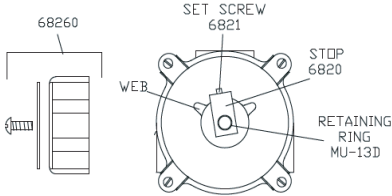
 <ol style="list-style-type: none"> 1. Remove handle, retaining ring and loosen set screw, and remove stop. 2. Turn emergency fixture on. 3. Replace handle on stem and turn stem until desired maximum temperature is reached. 4. Replace stop so it rests against the web on the LEFT side of the cover. 5. Set operating temperature, tighten set screw and resemble. 	<p style="text-align: center;">WARNING</p> <p>WARNING! This Thermostatic Mixing Valve has an adjustable high temperature limit stop which must be checked. If temperature is too high, the installer MUST RESET this stop immediately. Always check the temperature of the mixed water when the lever handle is turned to full HOT. Excessively hot water is DANGEROUS AND MAY CAUSE SCALDING!</p> <p>The high temperature limit stop is factory set at approximately 90°F (32°C) with an incoming hot water supply temperature of 135°F (57°C). If the incoming hot water on the job is higher than 135°F, the valve when turned to full hot will deliver water in excess of 90°F (32°C) and the high temperature limit stop MUST BE RESET BY THE INSTALLER.</p>
--	--

TROUBLESHOOTING INSTRUCTIONS

PACKINGS & GASKETS	Leak at pointer rod. Leak between valve cover and base.	PARTS REQUIRED:	
PORT SLEEVE ASSEMBLY	Valve outlet temperature cannot be adjusted or will not mix consistently.	MU-5A 6806	O'Ring (2 req.) Cover Gasket
THERMOSTAT GROUP	After cleaning or replacing port sleeve assembly, valve will not hold temperature.	TAG-1M Or KIT# R/TA/M	Port Sleeve Assembly Rebuilding kit
CHECKSTOPS	Hot water bypass in cold line. Supplies cannot be shut off completely. Leak at checkstop bonnet.	6810 Or KIT#R/TA/M	Thermostat Group Rebuilding kit
		KIT# 4/LVC KIT# B	(TA-300 / TA-350-LF) (TA-350)

SEE PAGE 5 FOR COMPLETE PARTS BREAKDOWN AND PARTS KITS

If installed on a circulated hot water system, make certain the valve is piped according to Leonard Required Methods of Piping (see page 3).

REMEMBER! THIS IS A CONTROL DEVICE WHICH MUST BE CLEANED AND MAINTAINED ON A REGULAR BASIS. (SEE MAINTENANCE GUIDE AND RECORD, MGR-1001).

REQUIRED METHOD OF PIPING TA VALVE

METHOD #1

Required when hot water is to be circulated to a thermostatic mixing valve which is a substantial distance from the hot water source.

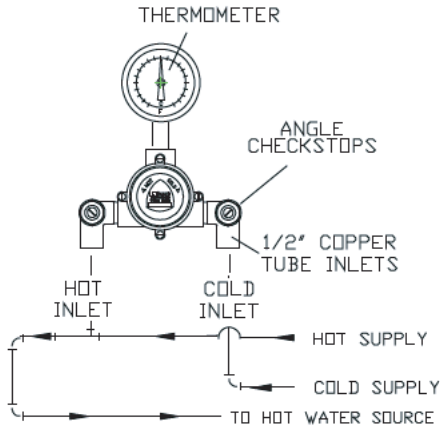

TA-300

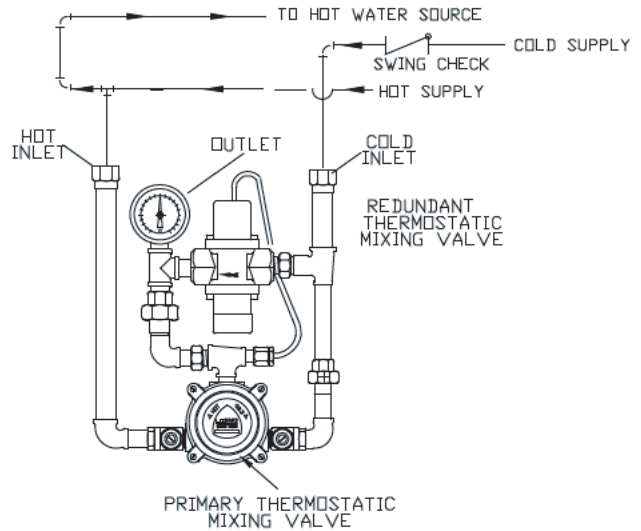

TA-350

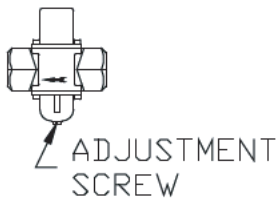

The TA-350 Redundant Thermostatic Mixing Valve has been factory set at 90°F (32°C). This set point can be field adjusted with a 3/8" wrench (see diagram). "Clockwise" direction will increase temperature. Maximum set point is 100°F (38°C). Consult medical advisor for correct temperature setting. As a secondary level of protection, in the event of redundant valve failure, installing contractor may wish to prevent cold water contamination by installing a swing check valve on the cold water supply to the valve (only needed on TA-350).

This unit must be cycled each time the emergency equipment is checked. See ANSI Z358.1, Maintenance and Training section.

Cycle redundant thermostat valve by, limit stop (see page 2) and setting the primary thermostatic mixing valve to full hot. (TA-350 only).
Open eye/face wash and check to be sure outlet temperature does not climb above 90°F (32°C).
Turn primary thermostatic valve to full cold and wait ten seconds.
Turn primary thermostatic valve to full hot and wait ten seconds.

Check to be sure outlet temperature does not climb above 90°F (32°C).
Turn primary thermostatic mixing valve to full cold and wait ten seconds.
Set primary thermostatic mixing valve to the desired temperature, adjust limit stop (see page 2) and close eye/face wash.

INSTRUCTIONS FOR DISMANTLING VALVE

Turn off hot and cold supplies to this valve. Remove four cover screws, lift off cover and thermostat group (DWG 1). After installing new parts, it will be necessary to reset Pointer to obtain correct temperature range from Cold to Hot. See page 2 instructions "TO RESET ADJUSTABLE HIGH TEMPERATURE LIMIT STOP."

TO CLEAN PORT SLEEVE ASSEMBLY

To clean port sleeve assembly (DWG 2.): Remove base stud. Back off port sleeve nut as far as it will go into base. Slide port sleeve assembly toward port sleeve nut and lift out of valve base. Clean port sleeve with a soft cloth; DO NOT use abrasives such as emery cloth or sandpaper. After cleaning, wash parts in clean water and reassemble in valve base. When reassembling port sleeve assembly BE SURE TO INSTALL WITH SHORT SLOT END IN BASE AND LONG SLOT END AT PORT SLEEVE NUT. Locate one set of port slots facing directly toward front of the valve. Tighten port sleeve nut just enough to hold port sleeve in place, (do not cramp or distort port sleeve by exerting excessive pressure when tightening port sleeve nut).

TO CLEAN THERMOSTAT GROUP

To clean thermostat group (DWG 1.), remove handle by loosening lock screw and pull off. Remove stop retaining ring and stop. Remove thermostat group by pushing rod through cover. **BE CAREFUL NOT TO PULL COILS OUT OF SHAPE.** If deposit has collected on thermostat coil, clean it off with a brush in cleaning solution and wash well before reassembly. Cleaning solution should be noncorrosive and grit free.

To reassemble: be sure, port sleeve assembly is in place and is working freely from side to side. Reinstall base stud, then place thermostat group on base stud and **BE SURE DRIVING BALL ON PORT SLEEVE ASSEMBLY TAG-1M IS INSERTED IN HOLE ON LOWER COIL BRACKET** (DWG 3.) Move thermostat back and forth to be sure all parts are free. Replace cover on valve base, install the four cover screws, and turn on hot and cold water supplies. See instructions below "To Reset High Temperature Limit Stop" to properly reset limit stop.

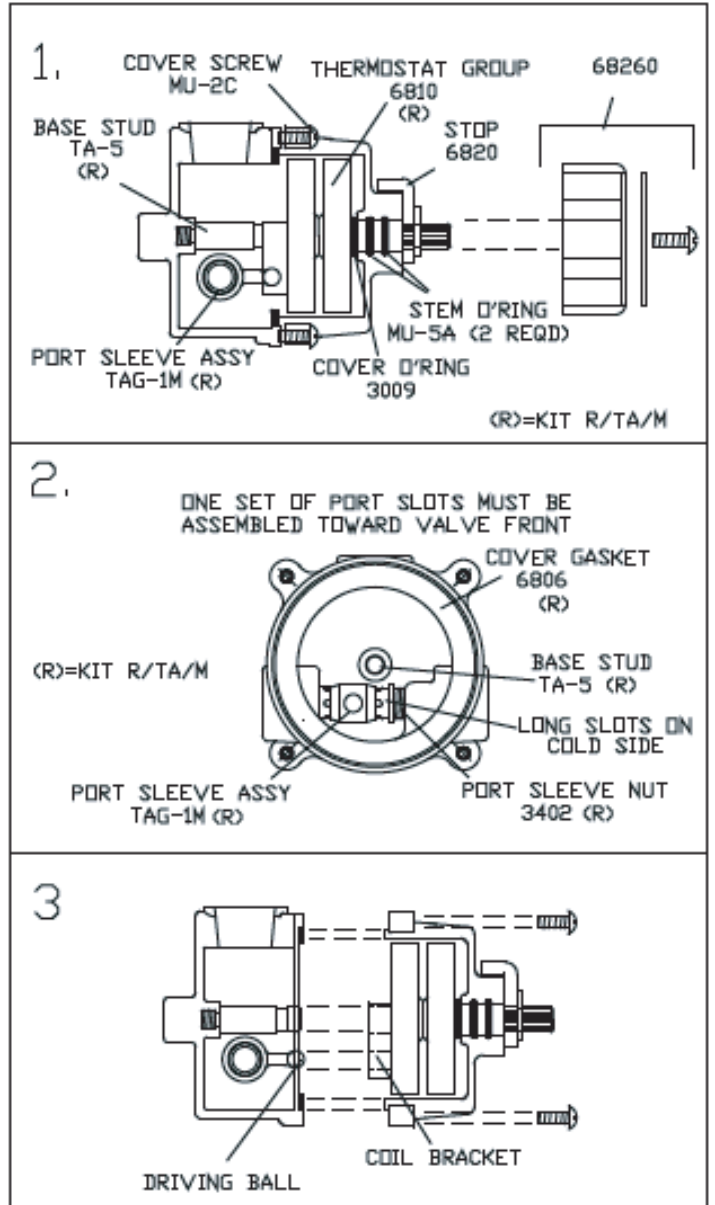

After installation, adjustment, and cleaning, always check the temperature of the valve when turned to full HOT per the warning on the front page, using a thermometer. Also check and if necessary adjust the temperature of the hot water source. **EXCESSIVELY HOT WATER (OVER 90oF) IS DANGEROUS AND MAY CAUSE SCALDING!!**

REMEMBER! THIS IS A CONTROL DEVICE WHICH MUST BE CLEANED AND MAINTAINED ON A REGULAR BASIS. (SEE MAINTENANCE GUIDE AND RECORD, MGR-1001).

VALVE PARTS

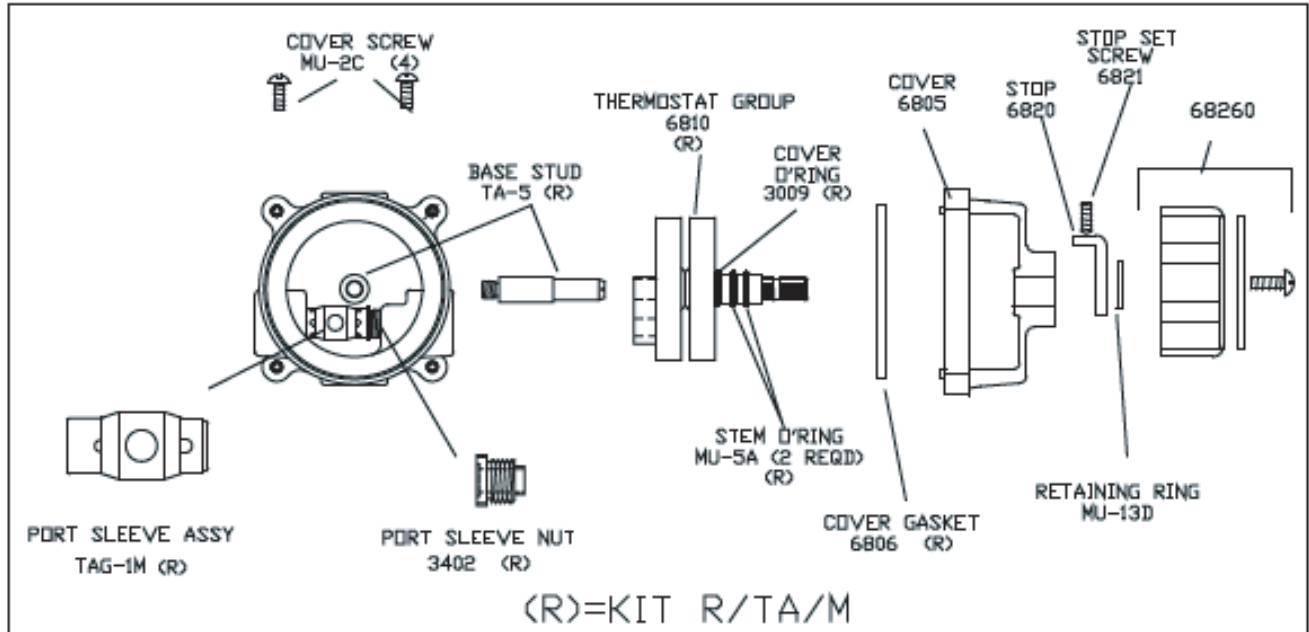

CHECKSTOP PARTS

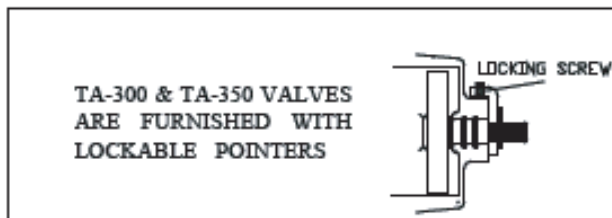
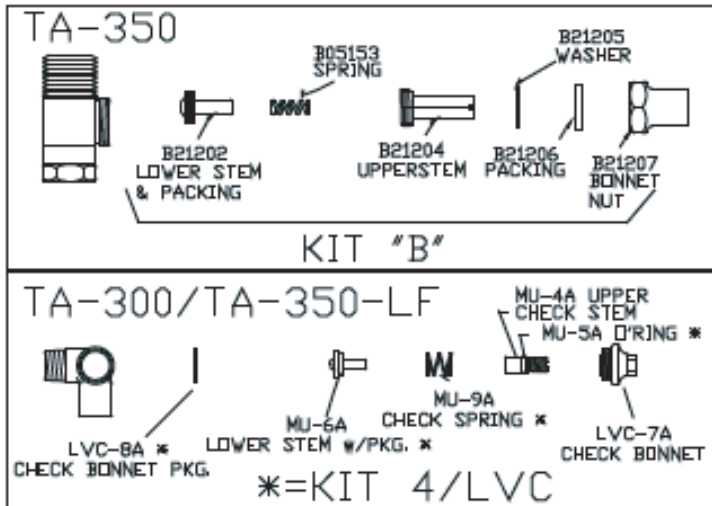

REPAIR KIT

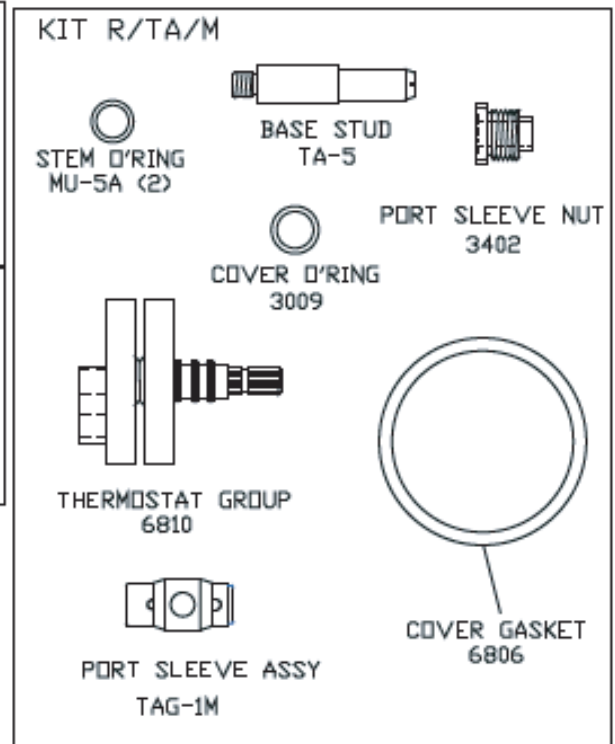

REMEMBER! THIS IS A CONTROL DEVICE WHICH MUST BE CLEANED AND MAINTAINED ON A REGULAR BASIS (SEE MAINTENANCE GUIDE AND RECORD, MGR-1001).

NOTE: AFTER INSTALLING NEW PARTS IT WILL BE NECESSARY TO RESET THE ADJUSTABLE HIGH TEMPERATURE LIMIT STOP, (SEE PAGE 2).

FLOW CAPACITIES

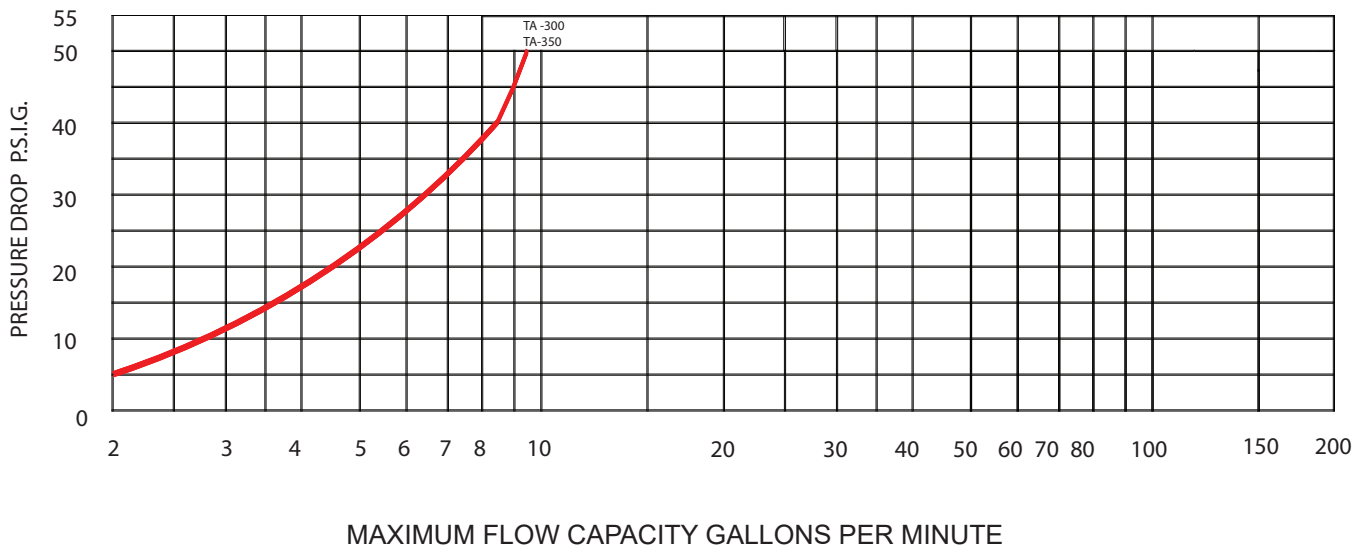

MODEL	IN	OUT	MINIMUM FLOW (GPM)	INTERNAL COLD WATER BY-PASS MINIMUM	PRESSURE DROP									
					5	10	15	20	25	30	35	40	45	PSI
					0.3	0.7	1.0	1.4	1.7	2.1	2.4	2.8	3.1	BAR
TA-300 TA-350	1/2"	1/2"	2.0	4	2.0	2.7	3.5	4.5	5.5	6.5	7.5	8.5	9.0	GPM
			7.6	15	7.6	10	13	17	21	25	28	32	34	L/MIN
MAXIMUM FLOW CAPACITY														

CAUTION! All thermostatic water mixing valves have limitations. They will not provide the desired accuracy outside of their flow capacity range. Consult the capacity chart and **DO NOT OVERSIZE**. Minimum flow must be no less than shown below.

IMPORTANT! These systems are designed to provide mixed water from 60 to 90°F (15 to 32°C) for face/eyewash applications only. Call Leonard for systems designed to operate at temperatures outside of this range.

LIMITED WARRANTY

Leonard Valve Company (hereinafter, "Leonard") warrants the original purchaser that products manufactured by Leonard will be free from defects in material or workmanship under normal conditions of use, when properly installed and maintained in accordance with Leonard's instructions, for a period of one year from the date of shipment. During this period, Leonard will at its option repair or replace any product, or part thereof, which shall be returned, freight prepaid, to the Leonard factory and determined by Leonard to be defective in materials or workmanship. Leonard provides no warranty, express or implied, which extends beyond the description contained herein. LEONARD SPECIFICALLY DISCLAIMS ANY AND ALL IMPLIED WARRANTIES OF MERCHANTABILITY OR OF FITNESS FOR A PARTICULAR PURPOSE. Nonetheless, some jurisdictions may not allow the disclaimer of certain implied warranties, in which case Leonard hereby limits such implied warranties to the duration of the limited warranty period contained herein. Some jurisdictions may not allow limitations on how long an implied warranty lasts, so the foregoing durational limitation may not apply to you. In no event will Leonard be liable for labor or incidental or consequential damages. Any alteration or improper installation or use of this product will void this limited warranty. If any provision of this limited warranty is prohibited by law in the applicable jurisdiction, such provision shall be null and void, but the remainder of this limited warranty shall continue in full force and effect.

1360 Elmwood Avenue, Cranston RI 02910 USA

Phone 401-461-1200 Fax 401-941-5310

EMAIL: info@leonardvalve.com WEB: <http://www.leonardvalve.com>

This page intentionally left blank.



Application

Ideal for use where Lead Free* valves are required. The Zurn Wilkins Model ZW3870XLT Aqua-Gard® Thermostatic mixing valve is designed to be installed at the point of use under sinks and sensor faucets to assist in the prevention of scalding. The valves rapid response and precise temperature control meet the stringent standards of ASSE 1070 listed for fixtures, sinks, lavatories or bathtubs. The ZW3870XLT will mix hot and cold water from the distribution system to a final safer temperature outlet range of 95-115F (35-46C). The 3/8" compression fittings make this valve ideal for residential and commercial applications. With a minimum flow rating of 0.06 GPM the valve will provide proper scald protection when used in conjunction with ultra low flow faucet aerators.

Standards Compliance:

- ASSE® Listed 1070
- cUPC® Listed
- CSA® Certified B125.70
- Meets the requirements of NSF/ANSI/CAN 61-9 Qs1*
*(0.25% MAX. WEIGHTED AVERAGE LEAD CONTENT)

Features:

Sizes: 3/8"
 Chrome Plated
 Outlet Temp. Range 95-115°F(35-46°C)
 Temperature Hot Supply 120-195°F max. (49-90.5°C)
 Temperature Cold Supply 40-75°F(4.4-23.8°C)
 Set Temperature Accuracy +/- 3°F(1.78°C)
 Max. Working Pressure (inlet) 145 psi
 Temperature must be field set
 Max. Pressure Differential is 15 psi between Hot & Cold inlets
 Flow rate @ 45 psi pressure loss 3.10 gpm
 Min. Flow Rate 0.06 gpm
 Integral check valves and strainer screen on hot and cold supply

ZW3870XLT 3 PORT (1 Hot in, 1 Cold in, 1 Mixed out)
 ZW3870XLT-4P 4 PORT (1 Hot in, 1 Cold in, 1 Cold out, 1 Mixed out.)

Dimensions & Weights (do not include pkg.)

MODEL	SIZE		DIMENSIONS (approximate)												WEIGHT	
			A		B		C		D		E		F			
	in.	mm	in.	mm	in.	mm	in.	mm	in.	mm	in.	mm	in.	mm	in.	mm
ZW3870XLT	3/8	9.5	4 27/32	123	4 3/16	106.3	5 55/64	149	2 1/32	52	2 27/32	72.2	2 1/2	64	1.2	.6

Flow Characteristic

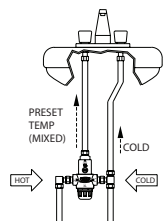
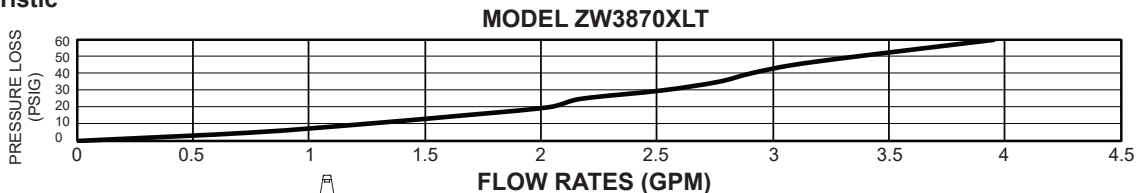

INDIVIDUAL USE
ZW3870XLT-4P

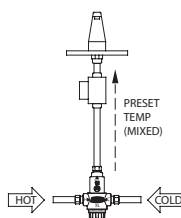

SINGLE USE
ZW3870XLT

Piping Instructions

The device is designed to be installed at a single outlet. It may be used to supply individual outlets when there is sufficient supply pressure. It is suggested to use ball valves on the hot and cold inlet supplies.



XL LEAD FREE



NSF/ANSI/CAN 61-9 Qs1



Materials

Body Low Lead Cast Bronze ASTM B 584 w/Chrome Plating
 Internal brass ASTM B 456 Service Condition #2
 Piston Low Lead Brass, ASTM B 927
 Guide Tube UNS C27450
 Spring Polysufone
 Checks Noryl GFN2
 Seals 300 Series Stainless Steel
 Viton
 Acetal Co-Polymer

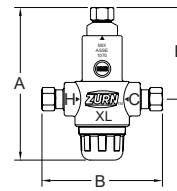

ZW3870XLT

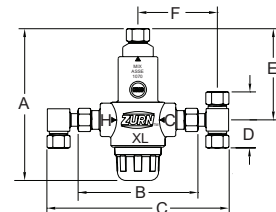

ZW3870XLT-4P