

PRODUCT SPECIFICATIONS

Elkay® 1-1/2" Drain Fitting Chrome Plated Brass with Rubber Stopper Ring and Chain. Overall dimensions are 2-1/8" x 2-1/8" x 8-1/2". Made of Brass.

Material:	Brass
Finish:	Chrome (CR)
Dimensions:	2-1/8" x 2-1/8" x 8-1/2"
Shipping Weight:	1 lbs.

Special Note: Arranged for overflow

- 1-1/4" O.D. x 6" chrome-plated brass tailpiece.



A Century of Tradition and Quality.

For more than 100 years, Elkay has been making innovative products and providing exceptional customer care. We take pride in offering plumbing products that make life easier, inspire change and leave the world a better place.

Product Compliance: ASME A112.18.2/CSA B125.2

[Clean and Care Manual \(PDF\)](#)

[Installation Instructions \(PDF\) - 100005235](#)

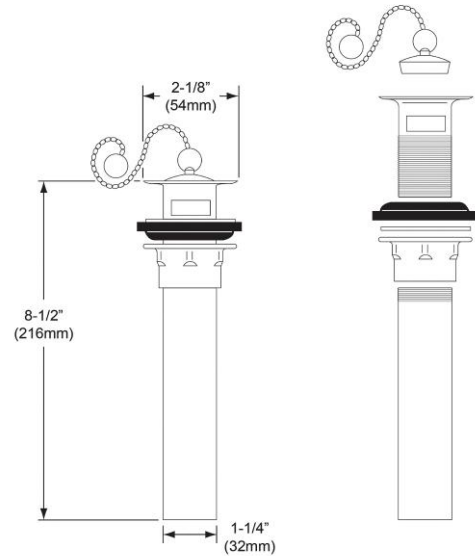

PART: _____ QTY: _____

PROJECT: _____

CONTACT: _____

DATE: _____

NOTES: _____

APPROVAL: _____

In keeping with our policy of continuing product improvement, Elkay reserves the right to change product specifications without notice. Please visit elkay.com for the most current version of Elkay product specification sheets. This specification describes an Elkay product with design, quality, and functional benefits to the user. When making a comparison of other producers' offerings, be certain these features are not overlooked.