

PRODUCT SPECIFICATIONS

Remote type, electric refrigerated water chiller unit. Chilling Capacity of 8.0 GPH (gallons per hour) of 50° F drinking water, based on 80° F inlet water and 90° F ambient, per ASHRAE 18 testing. Installs directly under fountain or other application, or may be located in service area to serve up to 2 remote outlets (within 15 feet recommended). Unit shall be certified to UL 399 and CAN/CSA C22.2 No. 120. Unit shall be lead-free design which is certified to NSF/ANSI 61 & 372 (lead free) and meets Federal and State low-lead requirements.

Compact, highly efficient water chiller units are designed for use where large quantities of chilled water are required.



Special Features:	Energy Savings, High Efficiency
Finish:	Galvanized Steel
Power:	115V/60Hz
Chilling Capacity*:	8.0 GPH
Rated Watts:	260
Dimensions:	13-1/4" x 10-1/4" x 17-1/8"
Approx. Shipping Weight:	43 lbs.
Installation Location:	Indoor
No. of Stations Served:	2
*Based on 80° F inlet water & 90° F ambient air temp for 50° F chilled drinking water.	

CONSTRUCTION

- Cabinet: Rust-resistant galvanized steel

COOLING SYSTEM

- Compressor: Hermetically-sealed, reciprocating type, single phase. Sealed-in lifetime lubrication.
- Condenser: Fan cooled, copper tube with aluminum fins. Fan motor is permanently lubricated.
- Cooling Unit: Combination tube-tank type. Continuous copper tubing is fully insulated with foam that meets UL requirements for self-extinguishing material.
- Temperature Control: Easily accessible enclosed adjustable thermostat is factory preset. Requires no adjustment other than for altitude requirements.

AMERICAN PRIDE. A LIFETIME TRADITION. Like your family, the Elkay family has values and traditions that endure. For almost a century, Elkay has been a family-owned and operated company, providing thousands of jobs that support our families and communities.



Included with Product: Water Chiller

PRODUCT COMPLIANCE

Buy American Act
CAN/CSA C22.2 No. 120
GreenSpec[®]
NSF/ANSI 61 & 372 (lead free)
UL 399



[Installation Instructions \(PDF\)](#)

5 Year Limited Warranty on the refrigeration system of the unit. Electrical components and water system are warranted for 12 months from date of installation. **Warranty pertains to drinking water applications only. Non-drinking water applications are not covered under warranty.**

[Warranty \(PDF\)](#)

OPTIONAL ACCESSORIES

EG1
EG2
PM3

PART: _____ QTY: _____
 PROJECT: _____
 CONTACT: _____
 DATE: _____
 NOTES: _____
 APPROVAL: _____

In keeping with our policy of continuing product improvement, Elkay reserves the right to change product specifications without notice. Please visit elkay.com for the most current version of Elkay product specification sheets. This specification describes an Elkay product with design, quality, and functional benefits to the user. When making a comparison of other producers' offerings, be certain these features are not overlooked.

Operating Pressures:

Supply water - recommended water pressure range is 40-105 psi

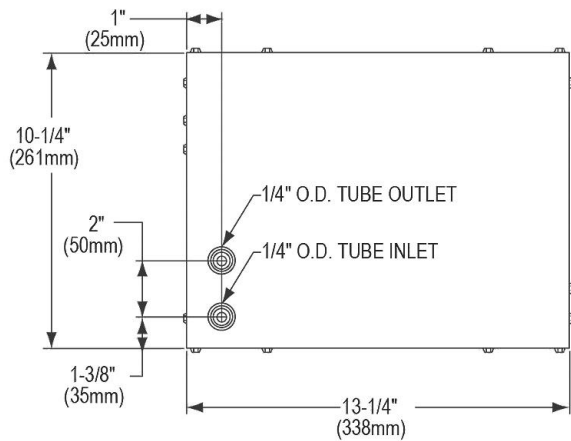

TOP VIEW

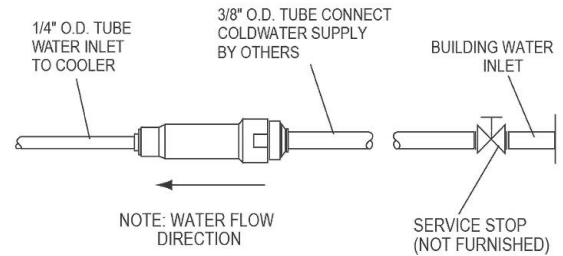

OPERATION OF QUICK CONNECT FITTINGS

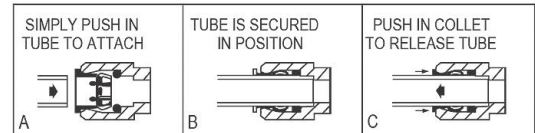

PUSHING TUBE IN BEFORE PULLING IT OUT HELPS TO RELEASE TUBE

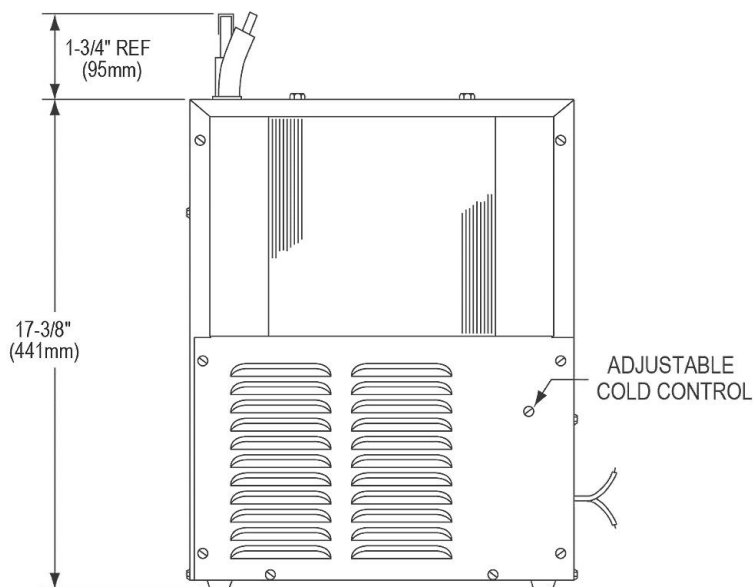

FRONT VIEW

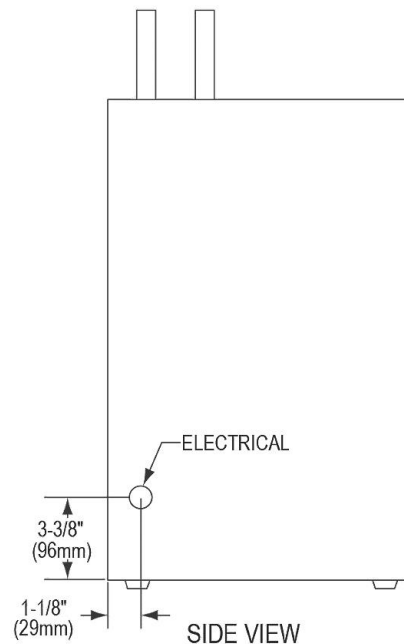

SIDE VIEW

NOTE: When mounting unit in an open area, to ensure proper ventilation, maintain a 4" (102mm) clearance from cabinet louvers on each side of chiller. When mounting unit in a cavity or behind a wall, maintain minimum space of 4" (102mm) on each side, 4" (102mm) on the top and a depth of 12" (305mm).

In keeping with our policy of continuing product improvement, Elkay reserves the right to change product specifications without notice. Please visit elkay.com for the most current version of Elkay product specification sheets. This specification describes an Elkay product with design, quality, and functional benefits to the user. When making a comparison of other producers' offerings, be certain these features are not overlooked.